

Service
Service
Service



Service Manual



Contents	Page	Contents	Page
1 Technical Specifications and Connection Facilities	2	AV Board - Bottom view layout	24
Location of PC Boards	2	AV Board - Circuit Diagram (Part 1)	25
Technical Specifications	3	AV Board - Circuit Diagram (Part 2)	26
Measurement Setup	4	AV Board - Circuit Diagram (Part 3)	27
Service Aids	5	AV Board - Circuit Diagram (Part 4)	28
Lead Free Requirements	7	AV Board - Circuit Diagram (Part 5)	29
2 Dismantling instructions & Service Positions	8	AV Board - Circuit Diagram (Part 6)	30
Dismantling instructions	8	8 Powerbox Spk Assy SW5500C	31
3 Diagnostic Software	10	Power Supply Unit - Top view layout	31
Service test program	10	Power Supply Unit - Circuit Diagram (Part 1)	32
4 Set Block diagram	13	Power Supply Unit - Circuit Diagram (Part 2)	33
5 Set wiring diagram	14	Interface - Top view layout	34
6 Panel Front Boards	15	Interface - Circuit Diagram (Part 1)	35
Front Display - Component Layout	15	Main Amplifier - Top view layout	36
Front Display - Chip Layout	15	Main Amplifier - Bottom view layout	37
Front Display - Circuit Diagram	16	Connector schematic	38
Key & Open/close Board - Component Layout	17	FR+SURROUND amplifier schematic	39
Key & Open/close Board - Chip Layout	17	Subwoofer Amplifier - Top view layout	40
Key & Open/close Board - Circuit Diagram	18	Subwoofer Amplifier - Bottom view layout	41
Front key board - Component Layout	19	Subwoofer amplifier schematic	42
Front key board - Chip Layout	19	Transformer - Top silk layout	43
Front key board - Circuit Diagram	20	Exploded View - Box Spk Assy SW5500C	44
Video Connector Board - Circuit Diagram	21	Exploded View - Module	45
Video Connector Board - Component Layout	22	Wiring Diagram SW5500C	46
Video Connector Board - Chip Layout	22	9 Module SD6.3 CH HT	47
7 AV Board	23	SD6.3 CH HT Board - Top View Layout	47
AV Board - Top view layout	23	SD6.3 CH HT Board - Bottom View Layout	48
		SD6.3 CH HT Board - Circuit Diagram (Part1)	49
		SD6.3 CH HT Board - Circuit Diagram (Part2)	50
		10 Set Mechanical Exploded View	51
		11 Partlist	53

©Copyright 2005 Philips Consumer Electronics B.V. Eindhoven, The Netherlands.
All rights reserved. No part of this publication may be reproduced, stored in a retrieval system or transmitted, in any form or by any means, electronic, mechanical, photocopying, or otherwise without the prior permission of Philips.



1. Technical Specifications and Connection Facilities

LOCATION OF PC BOARDS

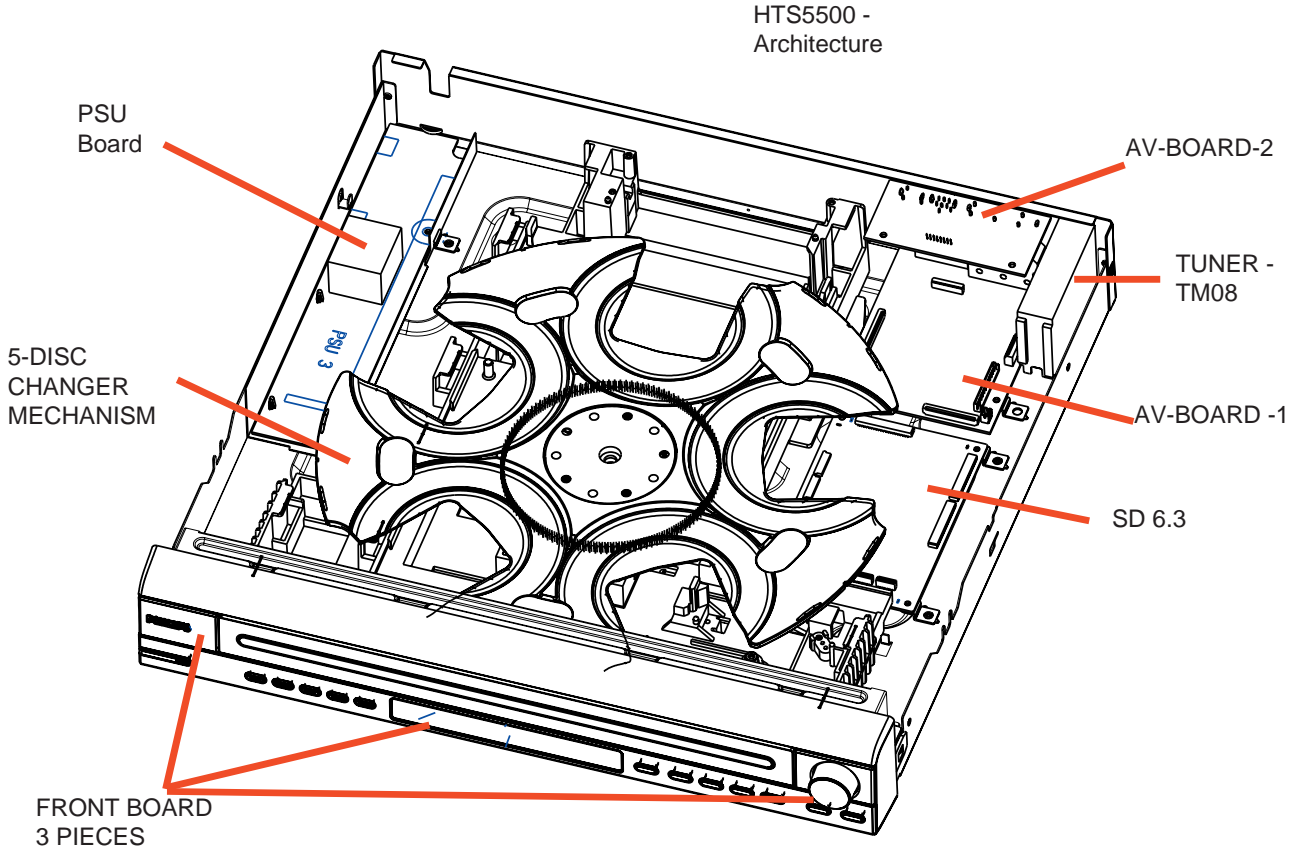

VERSION VARIATIONS:

Features & Board in used:	Type / Versions:	HTS5500C	
		37	55
Progressive Scan		X	X
Control Line To Power Box		X	X
Audio Output		X	X
Audio Input		X	X
Power Box (Easy Fit)		X	X
Video Output		X	X
S-Video Output		X	X
Y/Pb/Pr (YUV) Component Video Output		X	X

Technical Specifications

General:

Mains voltage	: 120V ± 15%
	240V ± 15%
Mains frequency	: 50/60Hz
Power consumption	: ≤ 0.5W at standby (Center Unit)
	≤ 0.5W at standby (Subwoofer)
	≤ 25W at 1/8 P _{rated} (Center Unit)
Dimension (w x h x d)	: 360 x 40 x 305mm

Tuner

FM

Tuning range	: 87.5-108MHz
Grid	: 50kHz /01 100kHz /97
IF frequency	: 10.7MHz ± 25kHz
Aerial input	: 75Ω coaxial
Sensitivity at 26dB S/N	: < 7μV
Selectivity at 600kHz bandwidth	: > 25dB
IF rejection	: > 60dB
Image rejection	: > 25dB
Distortion at RF=1mV, dev. 75kHz	: < 3%
-3dB Limiting point	: 8μV
Crosstalk at RF=1mV, dev. 67.5kHz	: > 28dB
Crosstalk at RF=1mV, dev. 40kHz	: > 18dB /97

MW

Tuning range	: 531-1602kHz 530-1700kHz for /97
Grid	: 9kHz 10kHz /97
IF frequency	: 450kHz ± 1kHz
Aerial input	: Frame aerial
Sensitivity at 26dB S/N	: < 4.0mV/m
Selectivity at 18kHz bandwidth	: > 20dB
IF rejection	: > 45dB
Image rejection	: > 28dB
Distortion at RF=50mV, m=80%	: < 5%

AMPLIFIER:

Output power	: 900W RMS
Front	: 150W RMS / channel
Rear	: 150W RMS / channel
Centre	: 150W RMS
Subwoofer	: 150W RMS
Frequency response	: 20Hz-50kHz / -3dB
Signal-to-noise ratio	: > 65dB (CCIR)

Input sensitivity

Aux In	: 1V at 39kΩ
Scart In	: 500mV at 39kΩ

Output sensitivity

Line Out (Left/Right)	: 0.7V ± 2dB at 47kΩ
Scart Out (Left/Right)	: 0.6V ± 2dB at 10kΩ

COMPACT DISC/VCD/DVD:

Video Decoding	: MPEG-1/MPEG-2/ MPEG-4/DivX 3.11, 4.x & 5.x
Video DAC	: 12 Bits, 108MHz
Signal System	: PAL / NTSC
Video Format	: 4:3 / 16:9
Video S/N	: 56dB (minimum)

CVBS Out ¹⁾

CVBS level	: 1.0 ± 0.1V _{p-p}
Luminance S/N	: ≥ 55dB

S-Video Out ¹⁾

Y level	: 1.0 ± 0.1V _{p-p}
Y S/N	: ≥ 60dB
C level (burst)	: 286mV _{p-p} +1/-4dB

RGB/YUV Out ¹⁾

Amplitude	: 0.7 ± 0.1V _{p-p}
S/N	: ≥ 60dB

¹⁾ Output terminals to be terminated with 75Ω

²⁾ @ THD = 10%, 1kHz Sinewave except Subwoofer @ 100Hz Sinewave

MEASUREMENT SETUP

Tuner FM

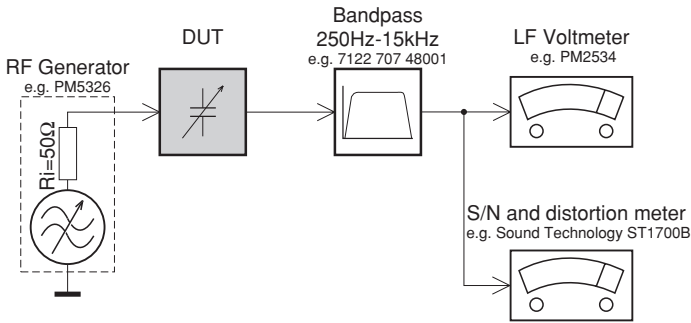

Use a bandpass filter to eliminate hum (50Hz, 100Hz) and disturbance from the pilotone (19kHz, 38kHz).

Tuner AM (MW,LW)

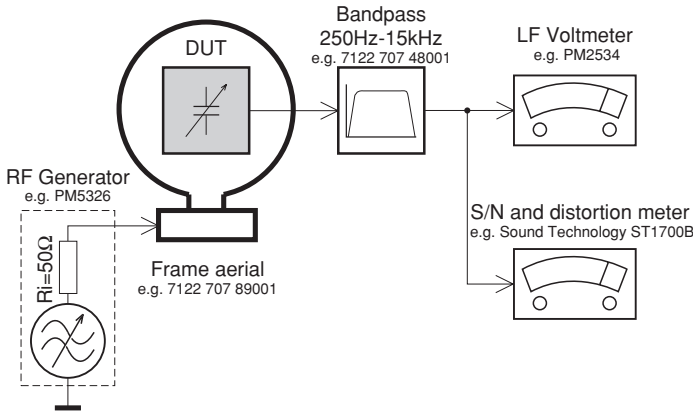

To avoid atmospheric interference all AM-measurements have to be carried out in a Faraday's cage. Use a bandpass filter (or at least a high pass filter with 250Hz) to eliminate hum (50Hz, 100Hz).

CD

Use Audio Signal Disc SBC429 4822 397 30184 (replaces test disc 3)

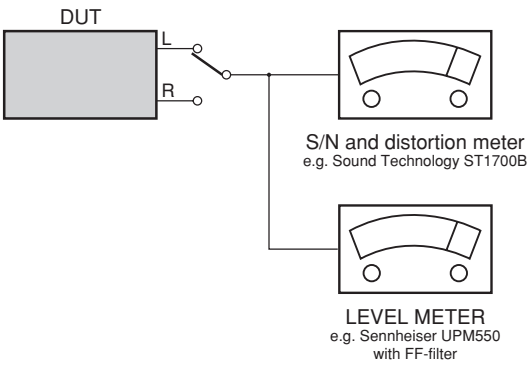

Recorder

Use Universal Test Cassette **CrO2** SBC419 4822 397 30069 or Universal Test Cassette **Fe** SBC420 4822 397 30071

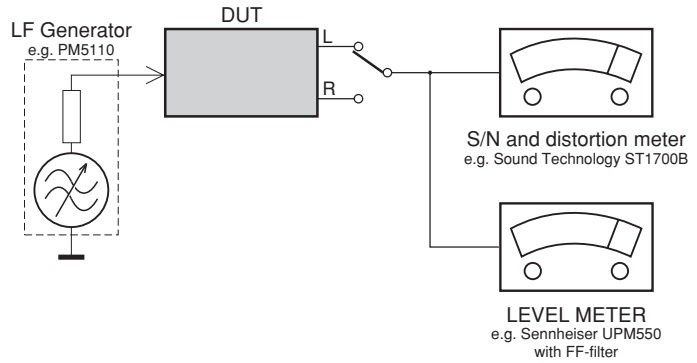

SERVICE AIDS

Service Tools:

- Universal Torx driver holder 4822 395 91019
- Torx bit T10 150mm 4822 395 50456
- Torx driver set T6 - T20 4822 395 50145
- Torx driver T10 extended 4822 395 50423

Compact Disc:

- SBC426/426A Test disc 5 + 5A 4822 397 30096
- SBC442 Audio Burn-in Test disc 1kHz 4822 397 30155
- SBC429 Audio Signals disc 4822 397 30184
- Dolby Pro-logic Test Disc 4822 395 10216

HANDLING CHIP COMPONENTS

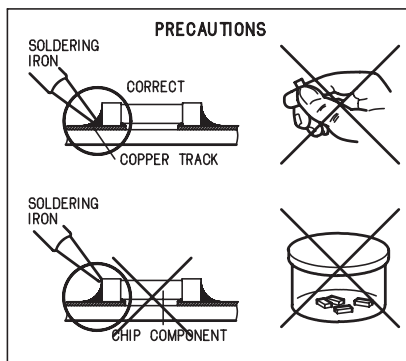
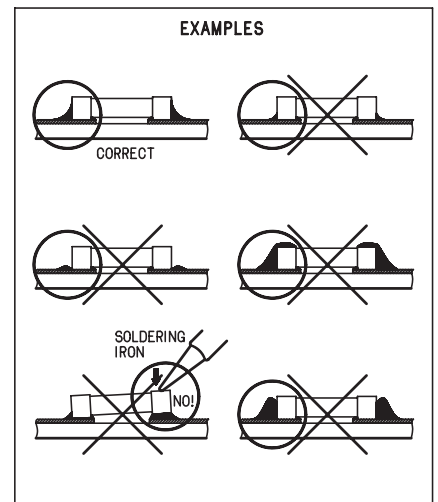
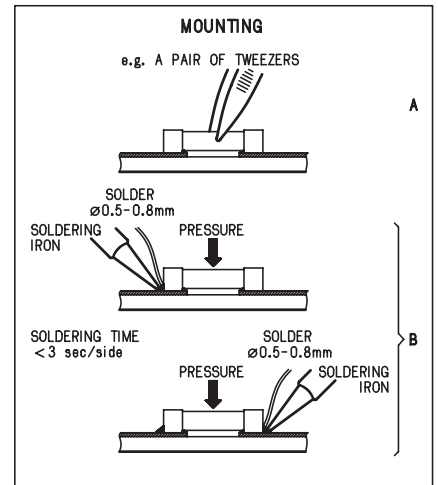
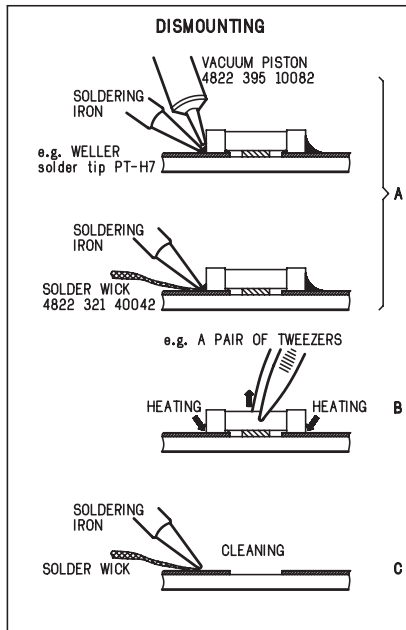
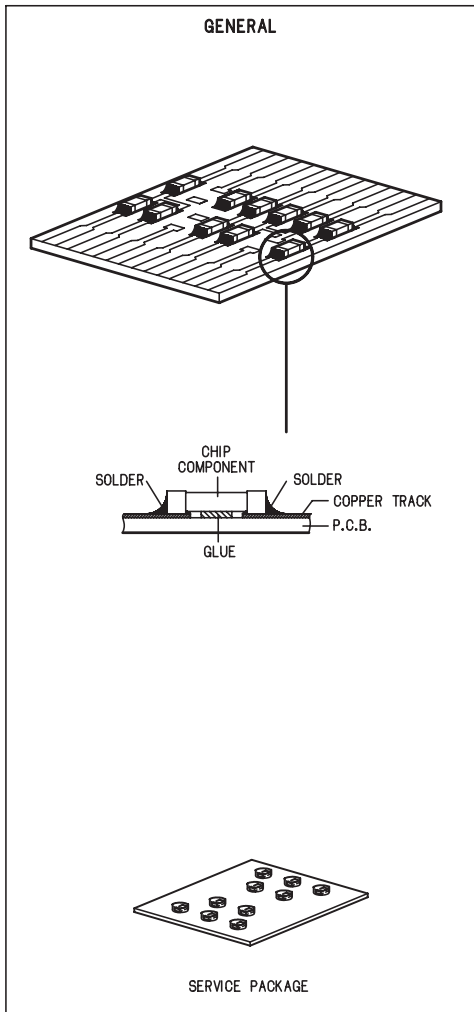

(GB) WARNING

All ICs and many other semi-conductors are susceptible to electrostatic discharges (ESD). Careless handling during repair can reduce life drastically.

When repairing, make sure that you are connected with the same potential as the mass of the set via a wrist wrap with resistance. Keep components and tools also at this potential.

ESD**(NL) WAARSCHUWING**

Alle IC's en vele andere halfgeleiders zijn gevoelig voor electrostatische ontladingen (ESD). Onzorgvuldig behandelen tijdens reparatie kan de levensduur drastisch doen verminderen. Zorg ervoor dat u tijdens reparatie via een polsband met weerstand verbonden bent met hetzelfde potentiaal als de massa van het apparaat.

Houd componenten en hulpmiddelen ook op hetzelfde potentiaal.

(F) ATTENTION

Tous les IC et beaucoup d'autres semi-conducteurs sont sensibles aux décharges statiques (ESD).

Leur longévité pourrait être considérablement écourtée par le fait qu'aucune précaution n'est prise à leur manipulation.

Lors de réparations, s'assurer de bien être relié au même potentiel que la masse de l'appareil et enfiler le bracelet serti d'une résistance de sécurité.

Veiller à ce que les composants ainsi que les outils que l'on utilise soient également à ce potentiel.

(D) WARNUNG

Alle ICs und viele andere Halbleiter sind empfindlich gegenüber elektrostatischen Entladungen (ESD).

Unvorsichtige Behandlung im Reparaturfall kann die Lebensdauer drastisch reduzieren.

Veranlassen Sie, dass Sie im Reparaturfall über ein Pulsarmband mit Widerstand verbunden sind mit dem gleichen Potential wie die Masse des Gerätes.

Bauteile und Hilfsmittel auch auf dieses gleiche Potential halten.

(I) AVVERTIMENTO

Tutti IC e parecchi semi-conduttori sono sensibili alle scariche statiche (ESD).

La loro longevità potrebbe essere fortemente ridotta in caso di non osservazione della più grande cauzione alla loro manipolazione.

Durante le riparazioni occorre quindi essere collegato allo stesso potenziale che quello della massa dell'apparecchio tramite un braccialetto a resistenza.

Assicurarsi che i componenti e anche gli utensili con quali si lavora siano anche a questo potenziale.

(GB) ESD PROTECTION EQUIPMENT:

Complete Kit ESD3 (small tablemat, wristband, connection box, extension cable and earth cable) 4822 310 10671
Wristband tester 4822 344 13999

(GB)

Safety regulations require that the set be restored to its original condition and that parts which are identical with those specified, be used

Safety components are marked by the symbol \triangle .

(NL)

Veiligheidsbepalingen vereisen, dat het apparaat bij reparatie in zijn oorspronkelijke toestand wordt teruggebracht en dat onderdelen, identiek aan de gespecificeerde, worden toegepast.

De Veiligheidsonderdelen zijn aangeduid met het symbool \triangle .

(F)

Les normes de sécurité exigent que l'appareil soit remis à l'état d'origine et que soient utilisées les pièces de rechange identiques à celles spécifiées.

Les composants de sécurité sont marqués \triangle .

(D)

Bei jeder Reparatur sind die geltenden Sicherheitsvorschriften zu beachten. Der Originalzustand des Geräts darf nicht verändert werden; für Reparaturen sind Original-Ersatzteile zu verwenden.

Sicherheitsbauteile sind durch das Symbol \triangle markiert.

(I)

Le norme di sicurezza esigono che l'apparecchio venga rimesso nelle condizioni originali e che siano utilizzati i pezzi di ricambio identici a quelli specificati.

Componenti di sicurezza sono marcati con \triangle .

(GB)

After servicing and before returning set to customer perform a leakage current measurement test from all exposed metal parts to earth ground to assure no shock hazard exist. The leakage current must not exceed 0.5mA.

**(GB) Warning !**

Invisible laser radiation when open.
Avoid direct exposure to beam.

(S) Varning !

Osynlig laserstrålning när apparaten är öppnad och spårren är urkopplad. Betrakta ej strålen.

(SF) Varoitus !

Avatussa laitteessa ja suojalukituksen ohitettaessa olet alltiina näkymättömälle laserisäteilylle. Älä katso säteeseen!

(DK) Advarse !

Usynlig laserstrålning ved åbning når sikkerhedsafbrydere er ude af funktion. Undgå udsættelse for strålning.

(F)

"Pour votre sécurité, ces documents doivent être utilisés par des spécialistes agréés, seuls habilités à réparer votre appareil en panne".

Lead Free Requirements

Pb(Lead) Free Solder

When soldering , be sure to use the pb free solder.

IDENTIFICATION:



Regardless of special logo (not always indicated)

one must treat all sets from **1 Jan 2005** onwards, according next rules:

Important note: In fact also products of year 2004 must be treated in this way as long as you avoid mixing solder-alloys (leaded/ lead-free). So best to always use SAC305 and the higher temperatures belong to this.

Due to lead-free technology some rules have to be respected by the workshop during a repair:

- Use only lead-free solder alloy Philips SAC305 with order code 0622 149 00106. If lead-free solder-paste is required, please contact the manufacturer of your solder-equipment. In general use of solder-paste within workshops should be avoided because paste is not easy to store and to handle.
 - Use only adequate solder tools applicable for lead-free solder alloy. The solder tool must be able
 - o To reach at least a solder-temperature of 400°C,
 - o To stabilize the adjusted temperature at the solder-tip
 - o To exchange solder-tips for different applications.
 - Adjust your solder tool so that a temperature around 360°C – 380°C is reached and stabilized at the solder joint. Heating-time of the solder-joint should not exceed ~ 4 sec. Avoid temperatures above 400°C otherwise wear-out of tips will rise drastically and flux-fluid will be destroyed. To avoid wear-out of tips switch off un-used equipment, or reduce heat.
 - Mix of lead-free solder alloy / parts with leaded solder alloy / parts is possible but PHILIPS recommends strongly to avoid mixed solder alloy types (leaded and lead-free).
If one cannot avoid or does not know whether product is lead-free, clean carefully the solder-joint from old solder alloy and re-solder with new solder alloy (SAC305).
 - Use only original spare-parts listed in the Service-Manuals. Not listed standard-material (commodities) has to be purchased at external companies.
 - Special information for BGA-ICs:
 - always use the 12nc-recognizable soldering temperature profile of the specific BGA (for de-soldering always use the lead-free temperature profile, in case of doubt)
 - lead free BGA-ICs will be delivered in so-called 'dry-packaging' (sealed pack including a silica gel pack) to protect the IC against moisture. After opening, dependent of MSL-level seen on indicator-label in the bag, the BGA-IC possibly still has to be baked dry. (MSL=Moisture Sensitivity Level). This will be communicated via AYS-website.
- Do not re-use BGAs at all.

- For sets produced before 1.1.2005 (except products of 2004), containing leaded solder-alloy and components, all needed spare-parts will be available till the end of the service-period. For repair of such sets nothing changes.
- On our website www.atyourservice.ce.Philips.com you find more information to:
 - BGA-de-/soldering (+ baking instructions)
 - Heating-profiles of BGAs and other ICs used in Philips-sets

You will find this and more technical information within the "magazine", chapter "workshop news".

For additional questions please contact your local repair-helpdesk.

2. Dismantling Instructions

2.1 Dismantling of the SD5.5_5dis changer

- 1) The tray can be manually open by inserting a minus screw drive and push the lever in the direction as shown in Figure 1 to unlock the tray before sliding it out.
- 2) Slide out the tray and remove the Cover Tray (pos 110) as shown in Figure 2.

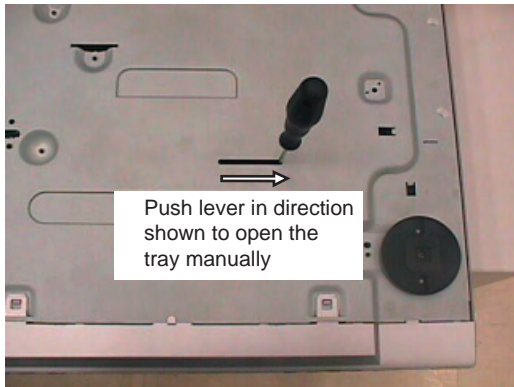

Figure 1

- 3) Loosen 7 screws to remove the Front Top.(pos 240)
 - 2 screw each on the left & right side (pos 272)
 - 3 screws A behind
- 4) Loosen 6 screws G (see Figure 4a and 4b) to remove the SD5.5_5dis changer.



Figure 2

2.2 Dismantling of the Tuner Module, AV Board, SD6.3 ,Front Board, PSU Module

- 1) Loosen 2 screw B (see Figure 3a) to remove the Tuner Module (pos 1040).
- 2) Loosen 4 screws C (see Figure 3b) to remove AV Board 1.
- 3) Loosen 4 screws D (see Figure 3c) and 2 screws H (see Figure 4a) to remove AV Board 2.
- 4) Loosen 2 screws E (see Figure 4a) to remove the PSU Module.
- 5) Loosen 6 screws I (see Figure 4a) and 4 snap hooks to remove Front Board.
 - 1 snap hook each on the left & right side (pos 161).
 - 2 snap hooks on the bottom side (pos 161).

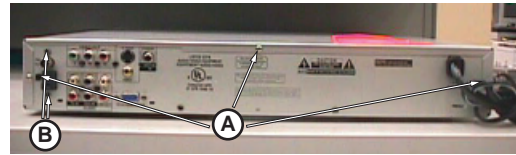

Figure 3a



Figure 3b

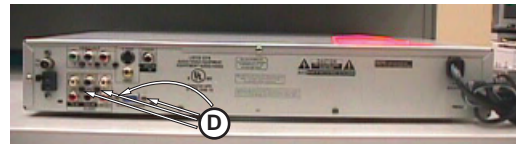

Figure 3c

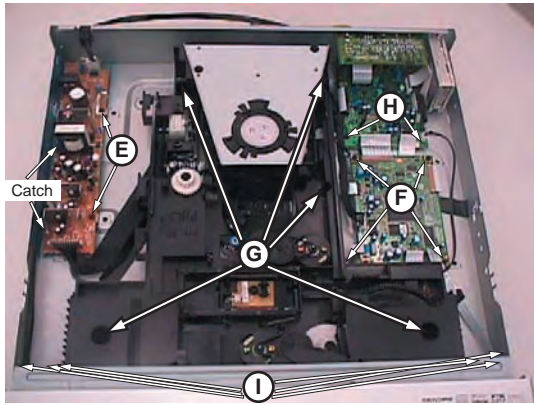

Figure 4a

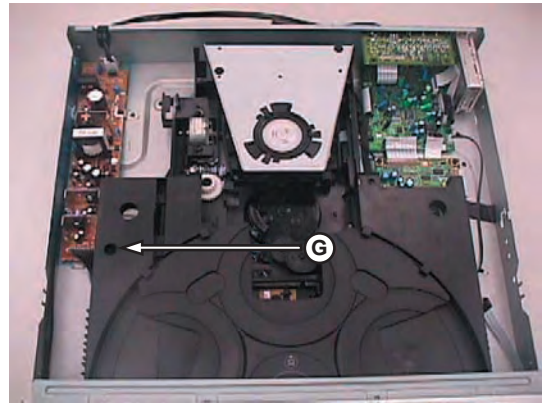

Figure 4b

2.3 Service Positions

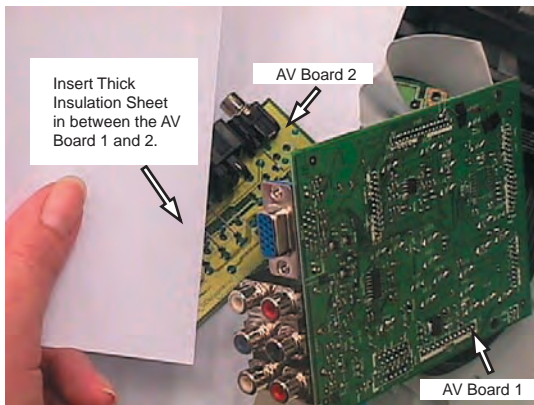

Figure 5

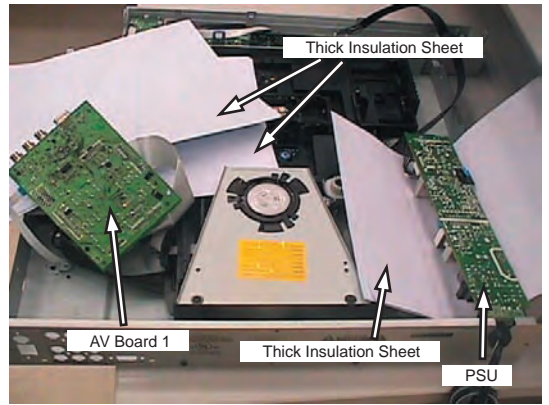

Figure 6

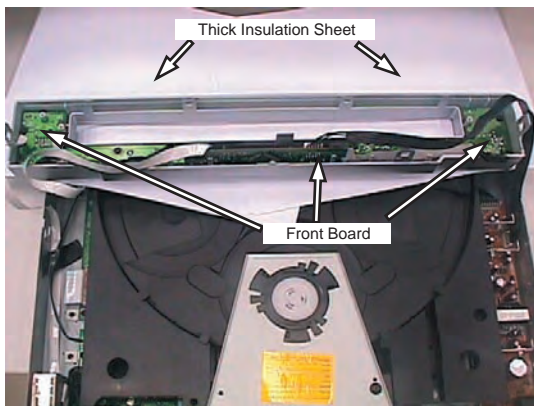

Figure 7

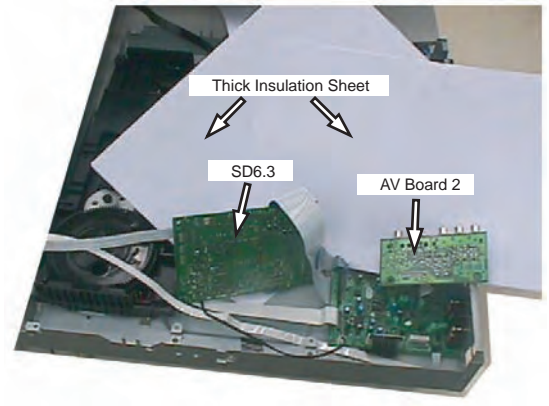

Figure 8

3. Diagnostic Software

Service test program

To start service test program hold open/close and buttons depressed while plugging in the mains cord

Hold open/close and buttons depressed till the Display shown "S-Vxx-yy"

Display shows "SERVICE" followed by ROM version "S-Vxx-yy"

S refers to Service Mode
 V refers to Version
 xx refers to Software version number of BEA (counting up from 01 to 99)
 yy refers to Software version number of Front uP (counting up from 01 to 99)

Main Menu

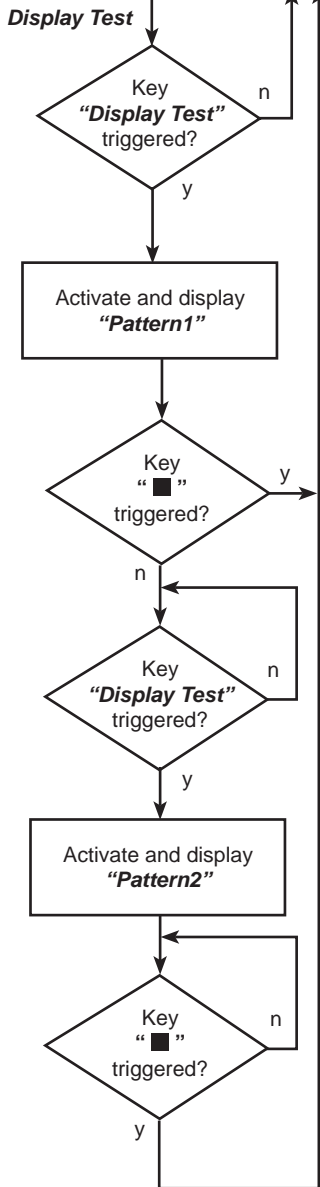

Display Test

Following display patterns are used to test the display and its connections to µP.

Pattern 1:

All display control pins are ON
 All LEDs are ON.
 - to check for open-circuits

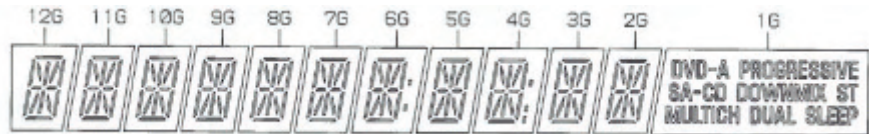

Pattern 2:

Alternate display control pins are ON (Test Pattern: 0x55)
 The following LEDs are ON:
 DiscAvailable1
 DiscAvailable3
 DiscAvailable5
 DiscActive2
 DiscActive4
 - to check for short-circuits

(tbd)

TEST	Activated with	ACTION
EEPROM FORMAT TEST	DISC 1	Load default data. Display shows "NEW". Caution! All presets from the customer will be lost!!
ROTARY ENCODER TEST	Volume Knob	Display shows value for 2 seconds. Volume values increases or decreases in steps of 1 until 0 (VOL MIN) or 40 (VOL MAX) is reached.
LEAVE SERVICE TEST PROGRAM	Disconnect mains cord	

Reprogramming of DVD version Matrix

After repair, the customer setting and region code may be lost. Reprogramming will put the set back in the state in which it has left the factory, ie. with the default setting and the allowed region code.

HTS5x00 Software Version Matrix						
	Model	Key Sequence	Region	Region Code	TV Type	PSCAN
1	HTS5500 C/37	Open Tray 9999 Audio 1	US	1	NTSC	yes
2	HTS5500 C/55	Open Tray 9999 Audio 2	LATAM	4	PAL	yes

To reprogram do as follows:

- 1) Power up the set and select **DISC** source.
- 2) Open tray by press "OPEN/CLOSE" button on the set or press and hold "STOP" button on the RC.
- 3) Press the following buttons on the Remote Control:
 <9> <9> <9> <9> <AUDIO> <1> for HTS5500C/37
 <9> <9> <9> <9> <AUDIO> <2> for HTS5500C/55
- 4) The display shows '**YYYY-ZZ**' and the tray will close.
YYYY = model number (eg. 8300, 8500, etc.)
ZZ = slash stroke version (eg. 01, 69, etc.)

Procedure for check Software version

- 1) Power up the set and select **DISC** source.
- 2) Open tray by press "OPEN/CLOSE" button on the set or press and hold "STOP" button on the RC.
- 3) Press "DISPLAY" button on the Remote control.
- 4) The TV screen will shows:

SD6.3 Vxx YYYY-ZZ A BB
SERVO: nnnnnnnn REG:A

xx = version number
 YYYY = model number (eg. 8300, 8500, etc.)
 ZZ = slash stroke version (eg. 01, 69, etc.)
 A = region code
 BB = Front uP software version number
 nnnnnnnn = servo version number

Procedure to upgrade software

- 1) Power up the set and select **DISC** source.
- 2) Open tray by press "OPEN/CLOSE" button on the set or press and hold "STOP" button on the RC.
- 3) Place Upgrade CD-ROM with filename "HTS5500.bin" onto tray and close.
- 4) The set will response and display the following:
 - **LOAD** (After the disc is read, the tray will open for you to remove the disc)
 - **ERASE** (Erasing disc)
 - **WRITE** (Writing disc)
 - **ERROR** (if upgrade is unsuccessful)
 - **UPG END** (if upgrade is successful)
 - **DISC->CLOSE->LOAD** (Tray will close indicating that the upgrade process is completed)
- 5) The whole process should not take more than 5 minutes.

Caution: Do not unplug the set until upgrade is completed.

Trade Mode

Trade mode is a feature that will block all set keys when enabled. It is for dealers to prevent customers from removing disc, changing source etc using the set keys. Rotary and Remote Control (RC) keys are still allowed in Trade mode.

To activate Trade Mode:

- 1) Power up the set and select **DISC** source.
- 2) Open tray by press "OPEN/CLOSE" button on the set or press and hold "STOP" button on the RC.
- 3) Then press buttons <2> <5> <9> on the RC.
- 4) The display shows '**TRA ON**' and the tray will close. Trade Mode is now enabled.

To deactivate Trade Mode:

- 1) Power up the set and select **DISC** source.
- 2) Open tray by press and hold "STOP" button on the RC.
- 3) Then press buttons <2> <5> <9> on the RC.
- 4) The display shows '**TRA OFF**' and the tray will close. Trade Mode is now disabled.

Procedure to change Tuner Grid (not for all versions)

In North and South America, the frequency step between adjacent channels in the MW band is 10kHz (9kHz in some areas). The preset frequency step in the factory is 9kHz.

IMPORTANT!

Changing the tuning grid will erase all previously stored preset radio stations.

- 1) Press **TUNER** on the remote (or press **SOURCE** control on front panel) to select "**FM**" or "**MW**".
- 2) Press **STANDY ON** to switch the DVD system to standby mode.
- 3) While holding down **SOURCE** and **PREV** on the front panel, disconnect and connect the power cord to the power supply again.
 -> The display will show "**GRID 9**" or "**GRID 10**".

Helpful hints:

- **GRID 9** and **GRID 10** indicate that the tuning grid is in step of 9kHz and 10kHz respectively.
- The **FM** tuning grid also will be changed from 50kHz to 100kHz or vice versa.

Notes:

4. Set Block diagram

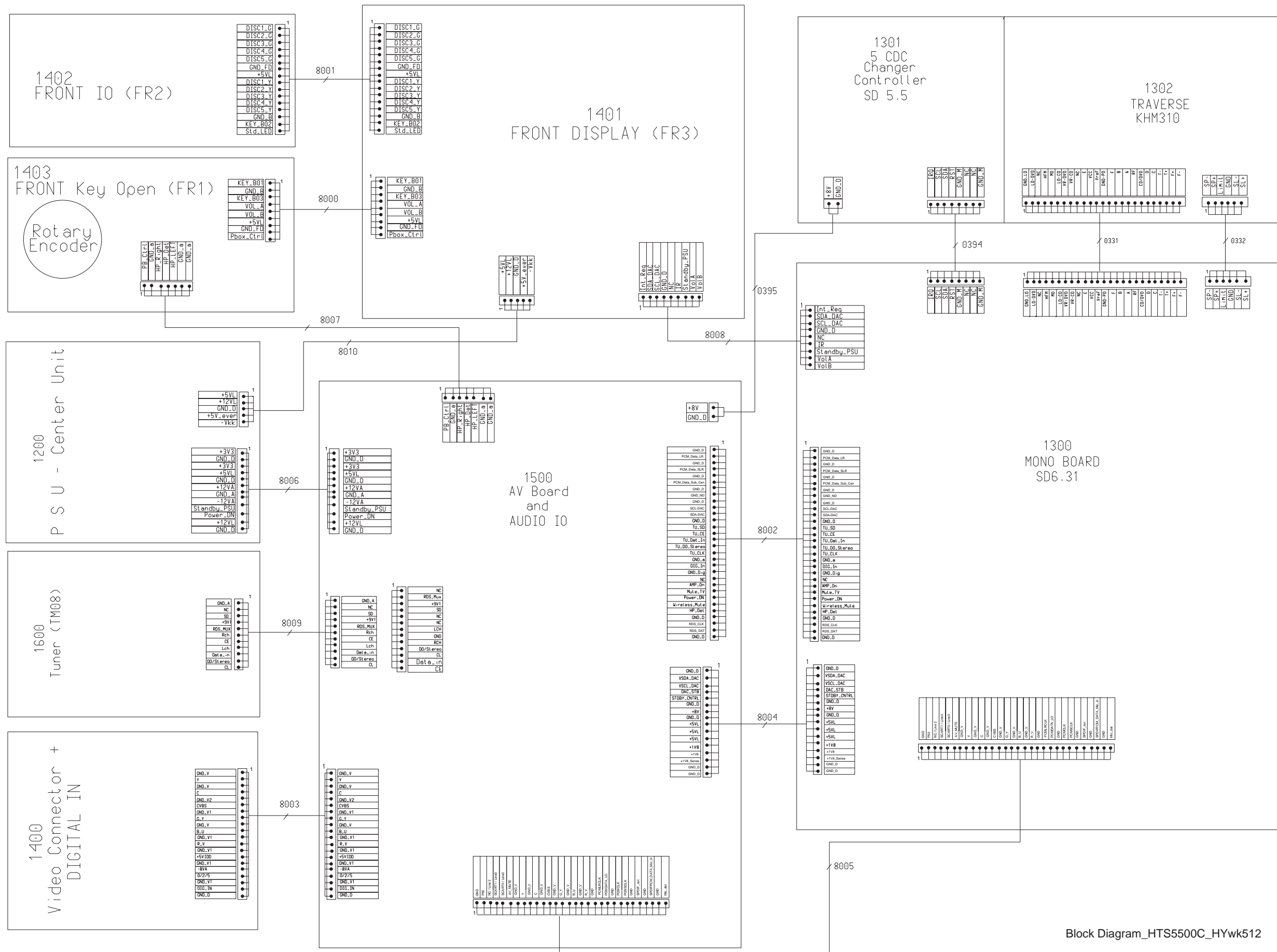

Block Diagram_HTS5500C_HYwk512

5. Set wiring diagram

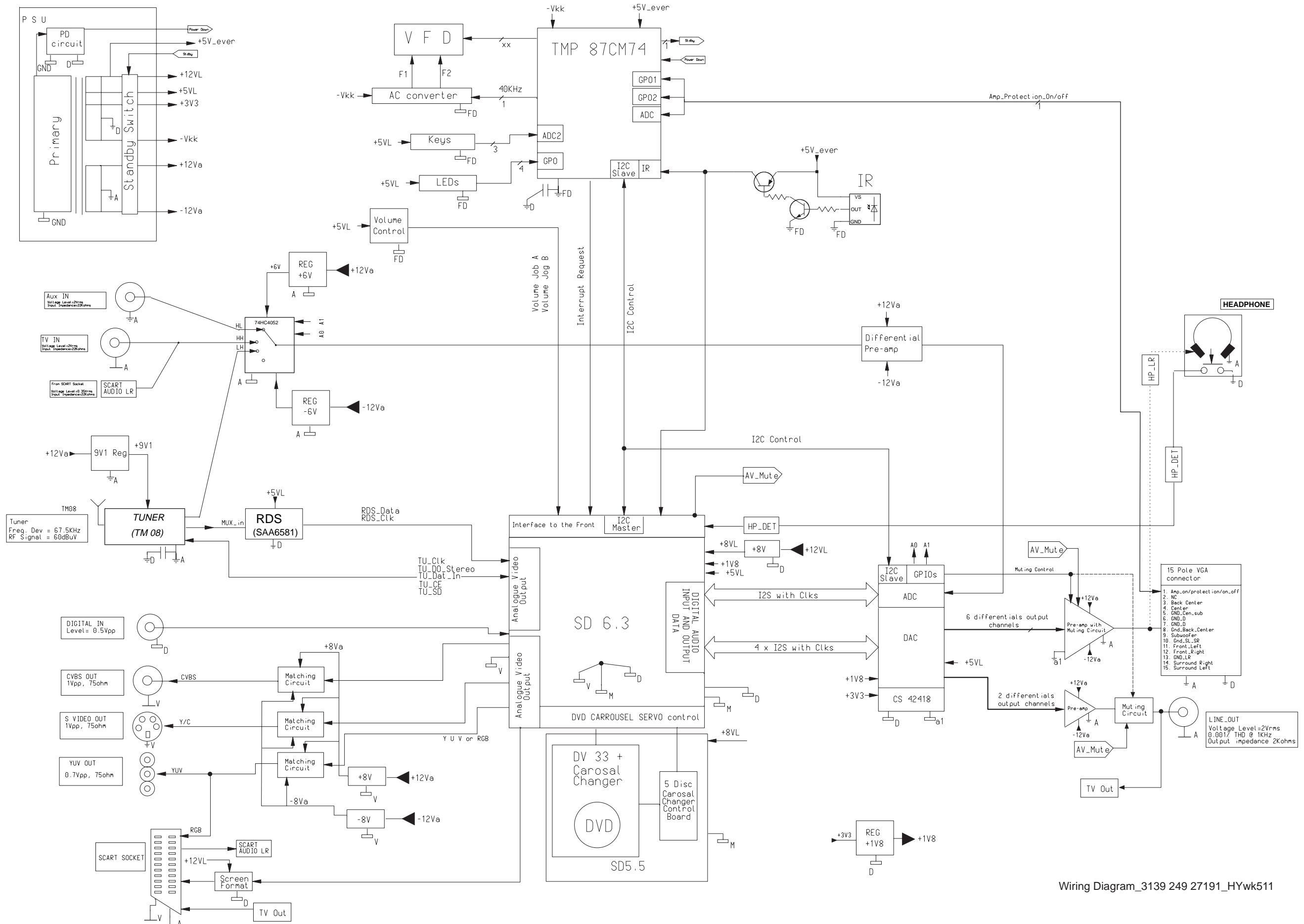

Wiring Diagram_3139 249 27191_HYwk511

6. Panel Front Boards Front Display - Component Layout

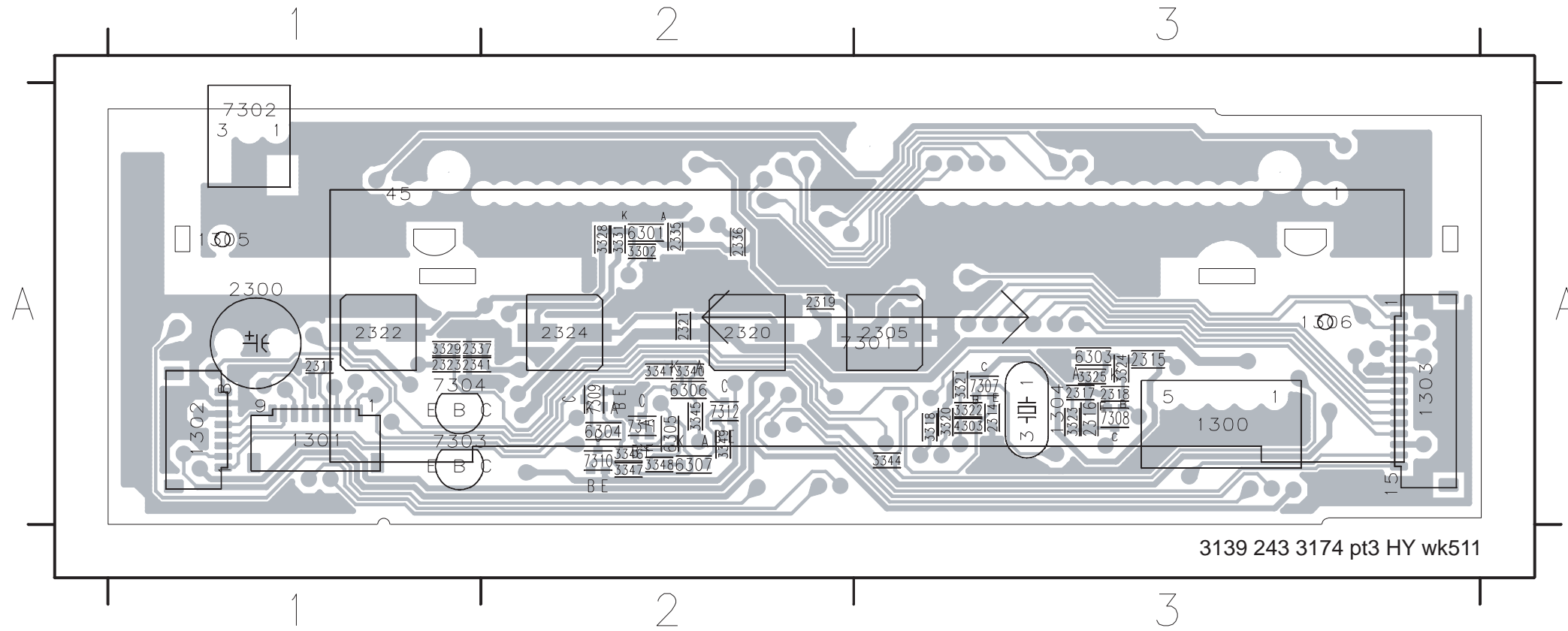

1300	A3	2341	A1	6305	A2
1301	A1	3302	A2	6306	A2
1302	A1	3318	A3	6307	A2
1303	A3	3320	A3	7301	A3
1304	A3	3321	A3	7302	A1
1305	A1	3322	A3	7303	A1
1306	A3	3323	A3	7304	A1
2300	A1	3324	A3	7307	A3
2305	A3	3325	A3	7308	A3
2311	A1	3328	A2	7309	A2
2314	A3	3329	A1	7310	A2
2315	A3	3331	A2	7311	A2
2316	A3	3340	A2	7312	A2
2317	A3	3341	A2		
2318	A3	3344	A3		
2319	A2	3345	A2		
2320	A2	3346	A2		
2321	A2	3347	A2		
2322	A1	3348	A2		
2323	A1	3349	A2		
2324	A2	4303	A3		
2335	A2	6301	A2		
2336	A2	6303	A3		
2337	A1	6304	A2		

Front Display - Chip Layout

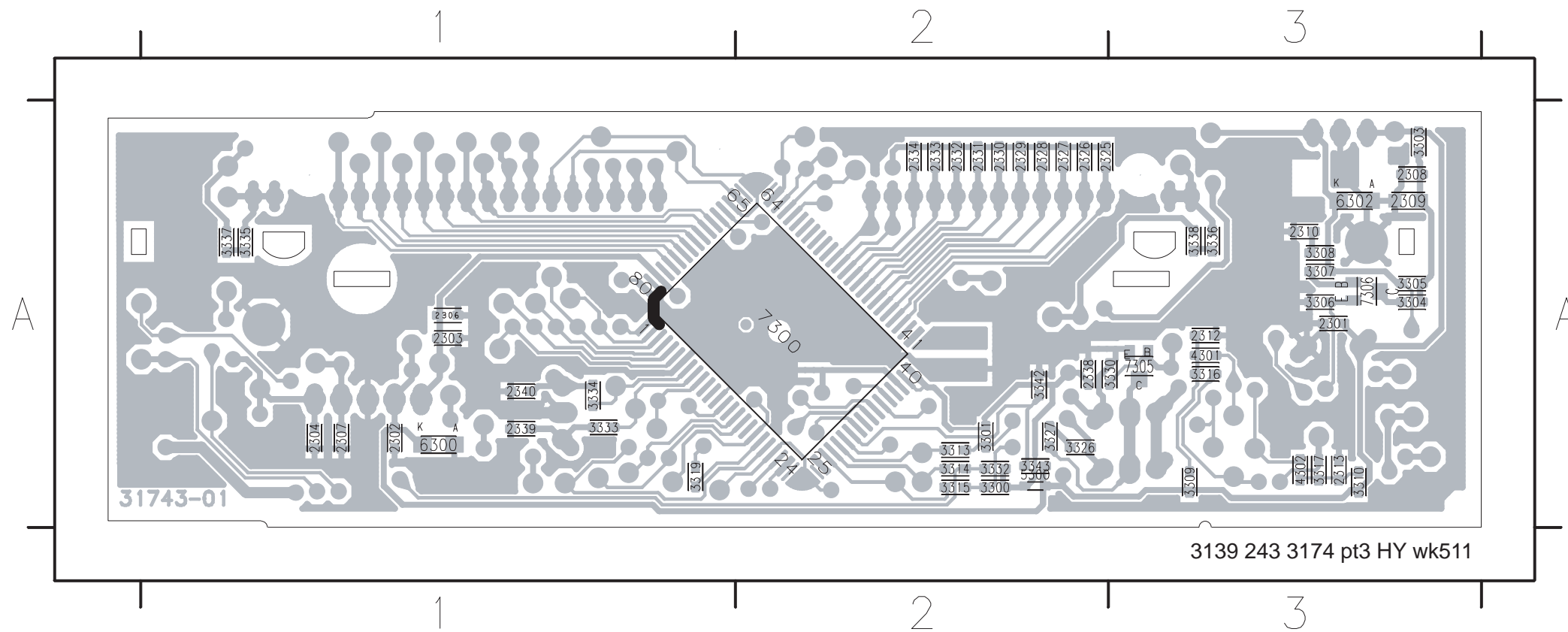

2301	A3	3300	A2	3337	A1
2302	A1	3301	A2	3338	A3
2303	A1	3303	A3	3342	A2
2304	A1	3304	A3	3343	A2
2306	A1	3305	A3	4301	A3
2307	A1	3306	A3	4302	A3
2308	A3	3307	A3	5300	A2
2309	A3	3308	A3	6300	A1
2310	A3	3309	A3	6302	A3
2312	A3	3310	A3	7300	A2
2313	A3	3313	A2	7305	A3
2325	A2	3314	A2	7306	A3
2326	A2	3315	A2		
2327	A2	3316	A3		
2328	A2	3317	A3		
2329	A2	3319	A1		
2330	A2	3326	A2		
2331	A2	3327	A2		
2332	A2	3330	A3		
2333	A2	3332	A2		
2334	A2	3333	A1		
2338	A2	3334	A1		
2339	A1	3335	A1		
2340	A1	3336	A3		

Front Display - Circuit Diagram

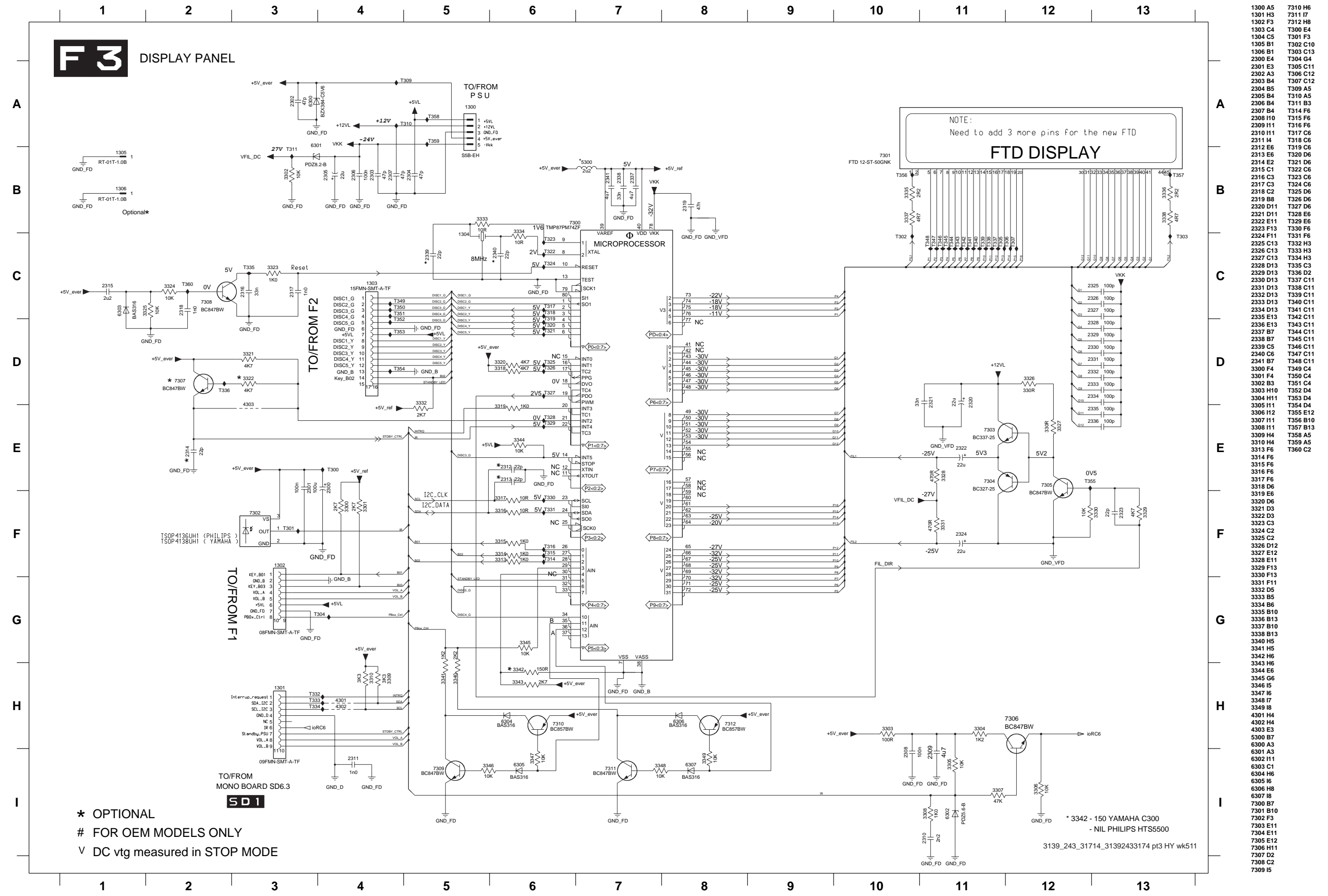

- 1300 A5
- 1301 H3
- 1302 F3
- 1303 C4
- 1304 C5
- 1305 B1
- 1306 B1
- 2300 E4
- 2301 E3
- 2302 A3
- 2303 B4
- 2304 B5
- 2305 B4
- 2306 B4
- 2307 B4
- 2308 I10
- 2309 I11
- 2310 I11
- 2311 I4
- 2312 E6
- 2313 E6
- 2314 E2
- 2315 C1
- 2316 C3
- 2317 C3
- 2318 C2
- 2319 B8
- 2320 D11
- 2321 D11
- 2322 E11
- 2323 F13
- 2324 F11
- 2325 C13
- 2326 C13
- 2327 C13
- 2328 D13
- 2329 D13
- 2330 D13
- 2331 D13
- 2332 D13
- 2333 D13
- 2334 D13
- 2335 E13
- 2336 E13
- 2337 B7
- 2338 B7
- 2339 C5
- 2340 C6
- 2341 B7
- 3300 F4
- 3301 F4
- 3302 B3
- 3303 H10
- 3304 H11
- 3305 I11
- 3306 I12
- 3307 I11
- 3308 I11
- 3309 H4
- 3310 H4
- 3311 F6
- 3312 F6
- 3313 F6
- 3314 F6
- 3315 F6
- 3316 F6
- 3317 F6
- 3318 D6
- 3319 E6
- 3320 D6
- 3321 D3
- 3322 D3
- 3323 C3
- 3324 C2
- 3325 C2
- 3326 D12
- 3327 E12
- 3328 E11
- 3329 F13
- 3330 F13
- 3331 F11
- 3332 D5
- 3333 B5
- 3334 B6
- 3335 B10
- 3336 B13
- 3337 B10
- 3338 B13
- 3340 H5
- 3341 H5
- 3342 H6
- 3343 H6
- 3344 E6
- 3345 G6
- 3346 I5
- 3347 I6
- 3348 I7
- 3349 I8
- 4301 H4
- 4302 H4
- 4303 E3
- 5300 B7
- 6300 A3
- 6301 A3
- 6302 I11
- 6303 C1
- 6304 H6
- 6305 I6
- 6306 H8
- 6307 I8
- 7300 B7
- 7301 B10
- 7302 F3
- 7303 E11
- 7304 E11
- 7305 E12
- 7306 H11
- 7307 D2
- 7308 C2
- 7309 I5
- 7310 H6
- 7311 I7
- 7312 H8
- T300 E4
- T301 F3
- T302 C10
- T303 C13
- T304 G4
- T305 C11
- T306 C12
- T307 C12
- T309 A5
- T310 A5
- T311 B3
- T314 F6
- T315 F6
- T316 F6
- T317 C6
- T318 C6
- T319 C6
- T320 D6
- T321 D6
- T322 C6
- T323 C6
- T324 C6
- T325 D6
- T326 D6
- T327 D6
- T328 E6
- T329 E6
- T330 F6
- T331 F6
- T332 H3
- T333 H3
- T334 H3
- T335 C3
- T336 D2
- T337 C11
- T338 C11
- T339 C11
- T340 C11
- T341 C11
- T342 C11
- T343 C11
- T344 C11
- T345 C11
- T346 C11
- T349 C4
- T350 C4
- T351 C4
- T352 D4
- T353 D4
- T354 D4
- T355 E12
- T356 B10
- T357 B13
- T358 A5
- T359 A5
- T360 C2

* OPTIONAL
 # FOR OEM MODELS ONLY
 √ DC vtg measured in STOP MODE

* 3342 - 150 YAMAHA C300
 - NIL PHILIPS HTS5500
 3139_243_31714_31392433174 pt3 HY wk511

Key & Open/Close Board - Component Layout

1200 A1	1203 A3	1206 A4	1209 A1	3215 A2	6202 A2	6205 A4	6208 A3	6211 A4
1201 A1	1204 A3	1207 A1	3211 A2	3217 A2	6203 A3	6206 A4	6209 A3	6212 A1
1202 A2	1205 A4	1208 A1	3213 A2	3219 A2	6204 A3	6207 A2	6210 A4	

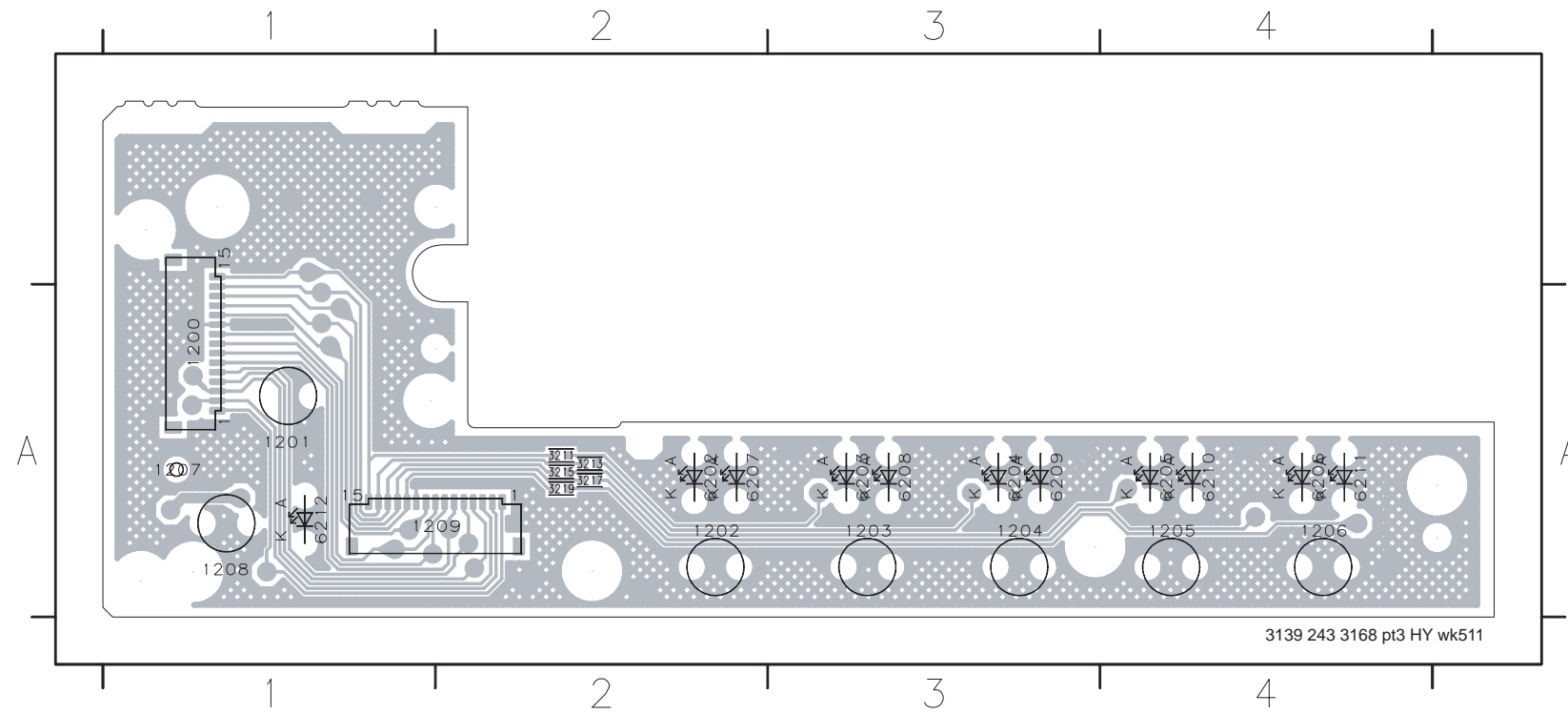

Key & Open/Close Board - Chip Layout

2200 A4	3202 A2	3205 A3	3208 A1	3212 A2	3218 A1	5200 A4	7200 A2	7203 A1
3200 A3	3203 A2	3206 A2	3209 A1	3214 A2	3220 A4	6200 A4	7201 A2	7204 A1
3201 A2	3204 A1	3207 A2	3210 A3	3216 A1	4200 A4	6201 A4	7202 A2	

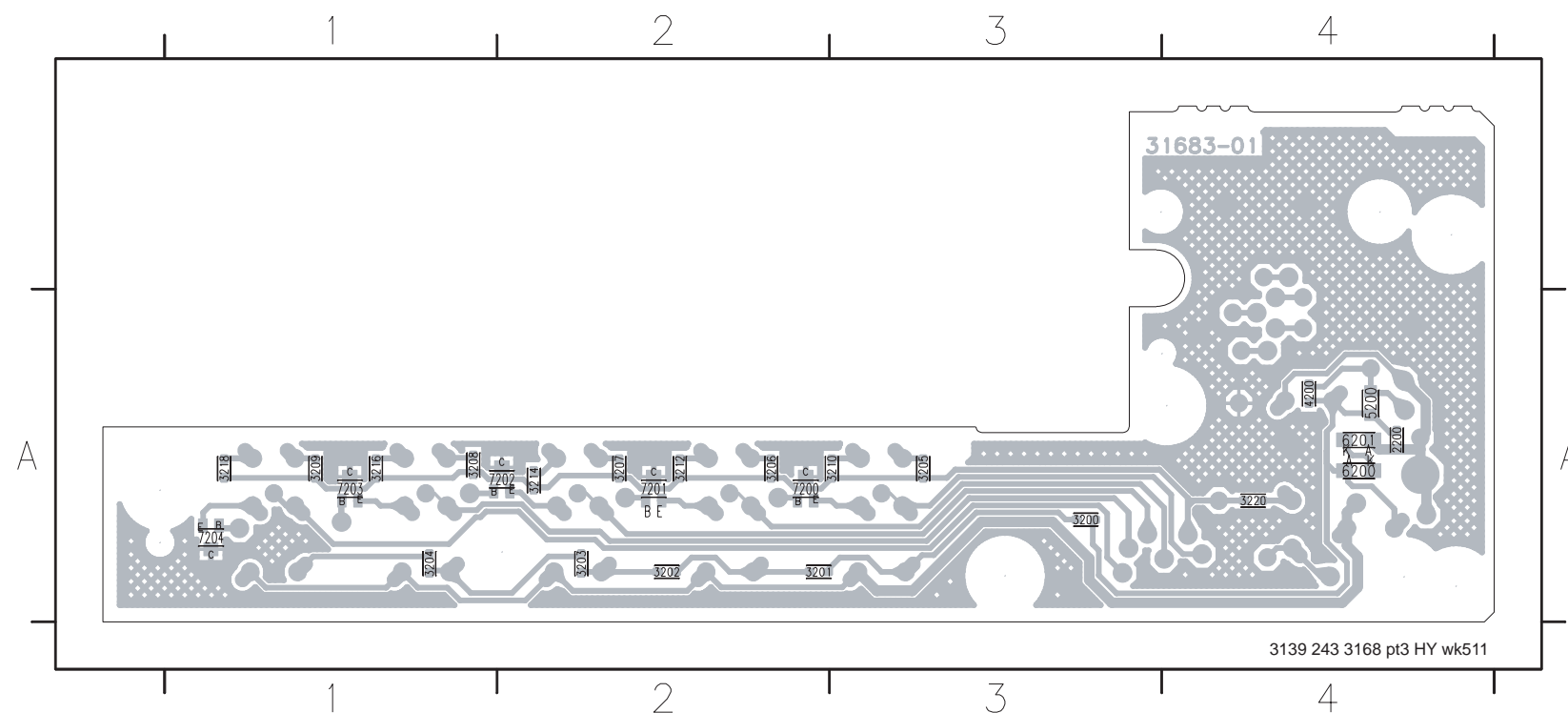

Key & Open/Close Board - Circuit Diagram

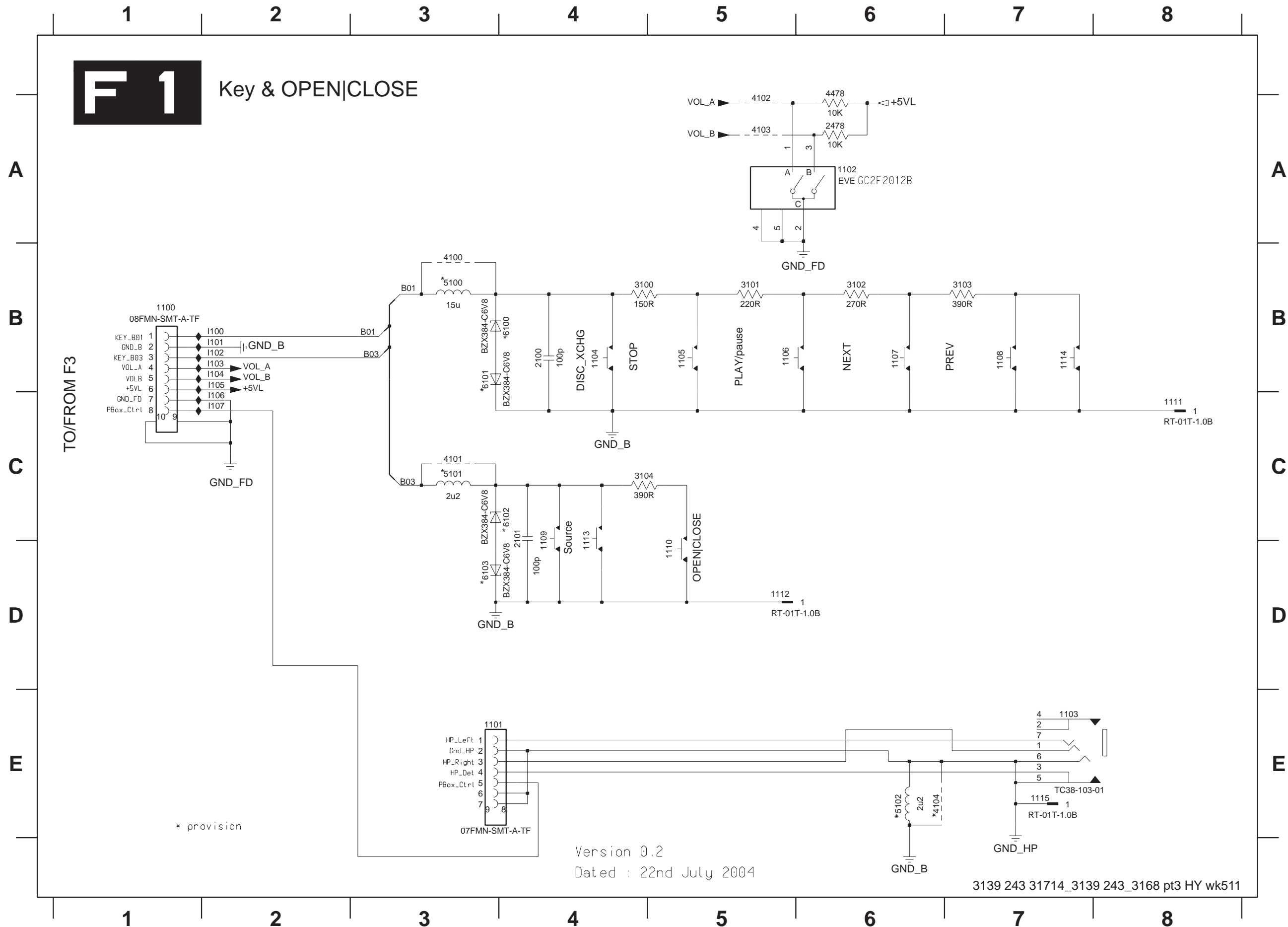

- 1100 B1
- 1101 E3
- 1102 A6
- 1103 E7
- 1104 B4
- 1105 B5
- 1106 B5
- 1107 B6
- 1108 B7
- 1109 C4
- 1110 D5
- 1111 C8
- 1112 D5
- 1113 C4
- 1114 B7
- 1115 E7
- 2100 B4
- 2101 C4
- 2478 A6
- 3100 B4
- 3101 B5
- 3102 B6
- 3103 B7
- 3104 C4
- 4100 B3
- 4101 C3
- 4102 A5
- 4103 A5
- 4104 E6
- 4478 A6
- 5100 B3
- 5101 C3
- 5102 E6
- 6100 B4
- 6101 B3
- 6102 C4
- 6103 D3
- 1100 B2
- 1101 B2
- 1102 B2
- 1103 B2
- 1104 B2
- 1105 B2
- 1106 C2
- 1107 C2

Front key board - Component Layout

1100 A4 1102 A4 1104 A4 1106 A2 1108 A1 1110 A4 1112 A2 1114 A1
 1101 A4 1103 A1 1105 A3 1107 A2 1109 A4 1111 A3 1113 A1 1115 A3

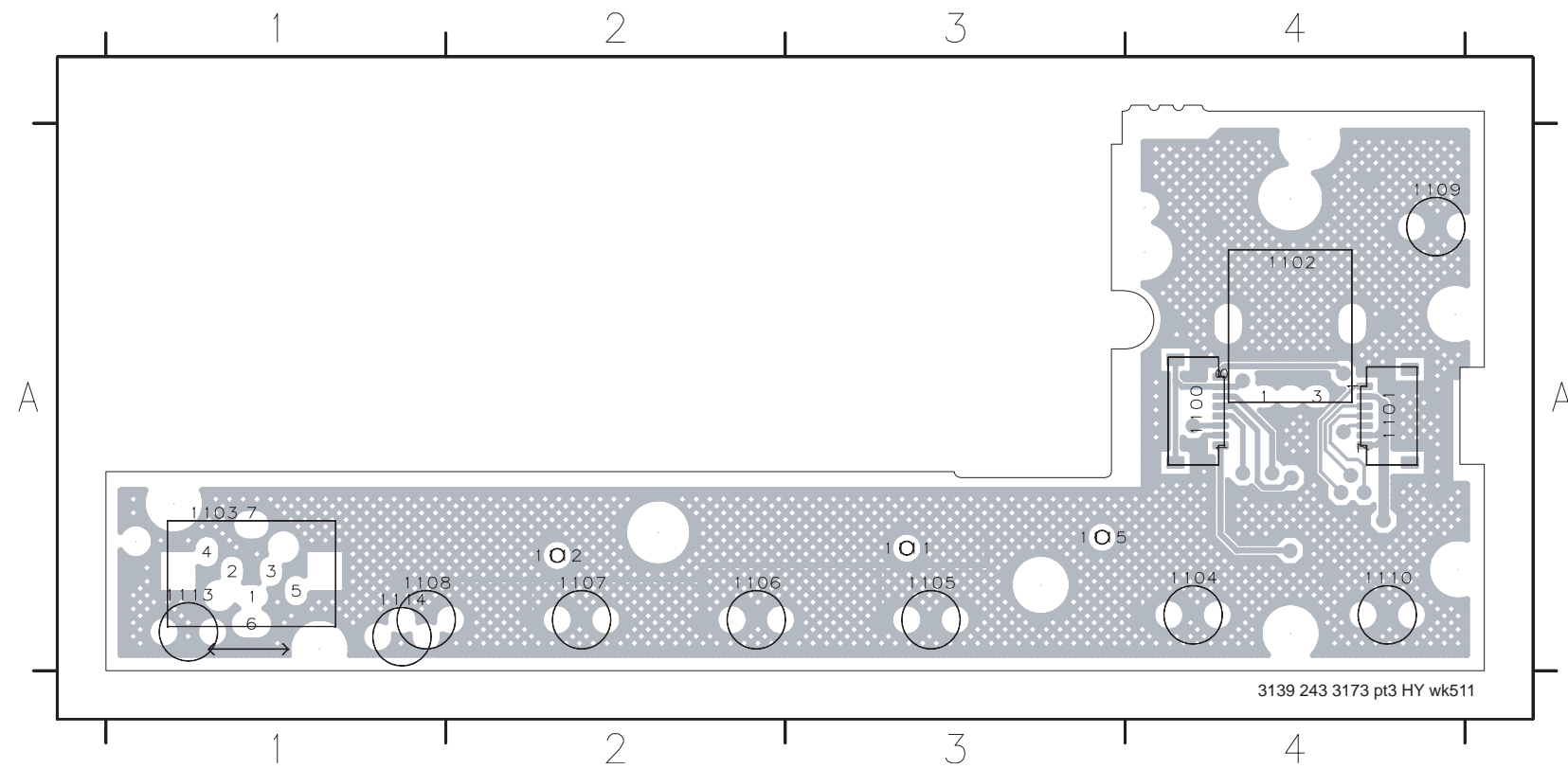

Front key board - Chip Layout

2100 A1 2478 A1 3101 A2 3103 A3 4100 A1 4102 A1 4104 A4 5100 A1 5102 A4 6101 A1 6103 A1
 2101 A1 3100 A2 3102 A3 3104 A1 4101 A1 4103 A1 4478 A1 5101 A1 6100 A1 6102 A1

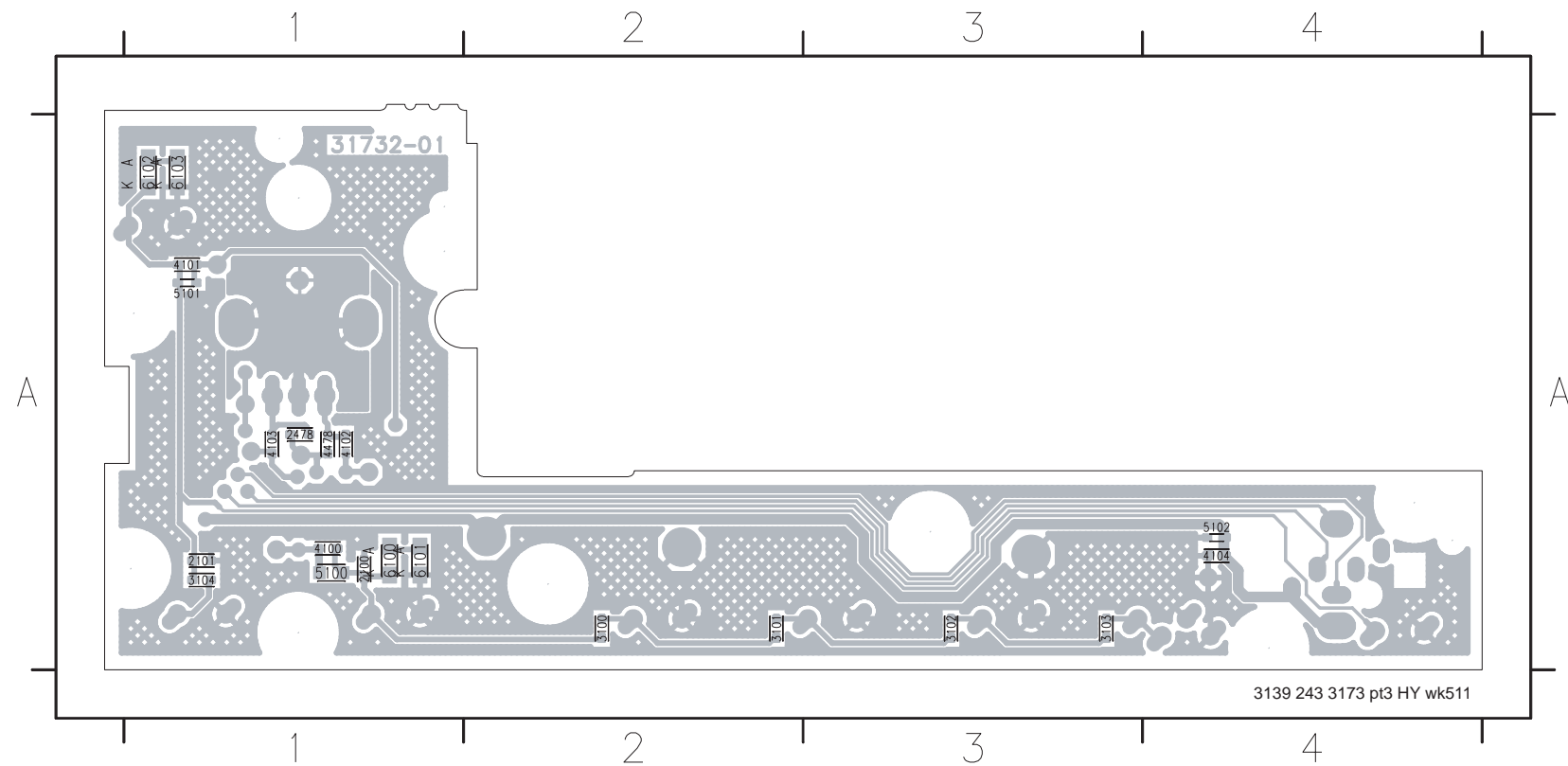

Front key board - Circuit Diagram

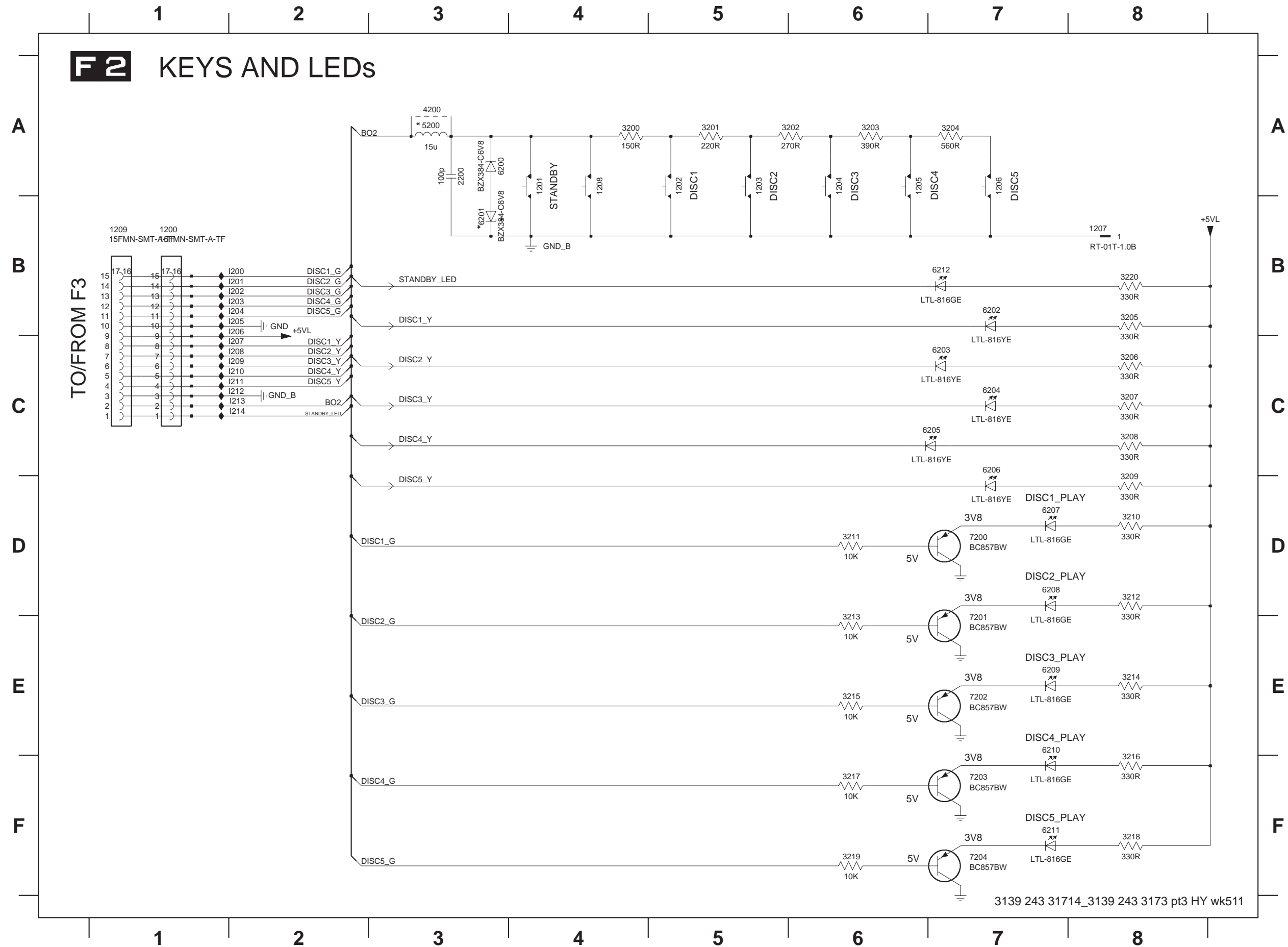

- 1200 B1
- 1201 A4
- 1202 A5
- 1203 A5
- 1204 A6
- 1205 A6
- 1206 A7
- 1207 B8
- 1208 A4
- 1209 B1
- 2200 A3
- 3200 A4
- 3201 A5
- 3202 A6
- 3203 A6
- 3204 A7
- 3205 B8
- 3206 C8
- 3207 C8
- 3208 C8
- 3209 D8
- 3210 D8
- 3211 D6
- 3212 D8
- 3213 E6
- 3214 E8
- 3215 E6
- 3216 F8
- 3217 F6
- 3218 F8
- 3219 F6
- 3220 B8
- 4200 A3
- 5200 A3
- 6200 A3
- 6201 B3
- 6202 B7
- 6203 C7
- 6204 C7
- 6205 C7
- 6206 C7
- 6207 D7
- 6208 D7
- 6209 E7
- 6210 E7
- 6211 F7
- 6212 B7
- 7200 D7
- 7201 D7
- 7202 E7
- 7203 F7
- 7204 F7
- I200 B2
- I201 B2
- I202 B2
- I204 B2
- I205 B2
- I206 B2
- I207 C2
- I208 C2
- I209 C2
- I210 C2
- I211 C2
- I212 C2
- I213 C2
- I214 C2

3139 243 31714_3139 243 3173 pt3 HY wk511

Video Connector Board - Circuit Diagram

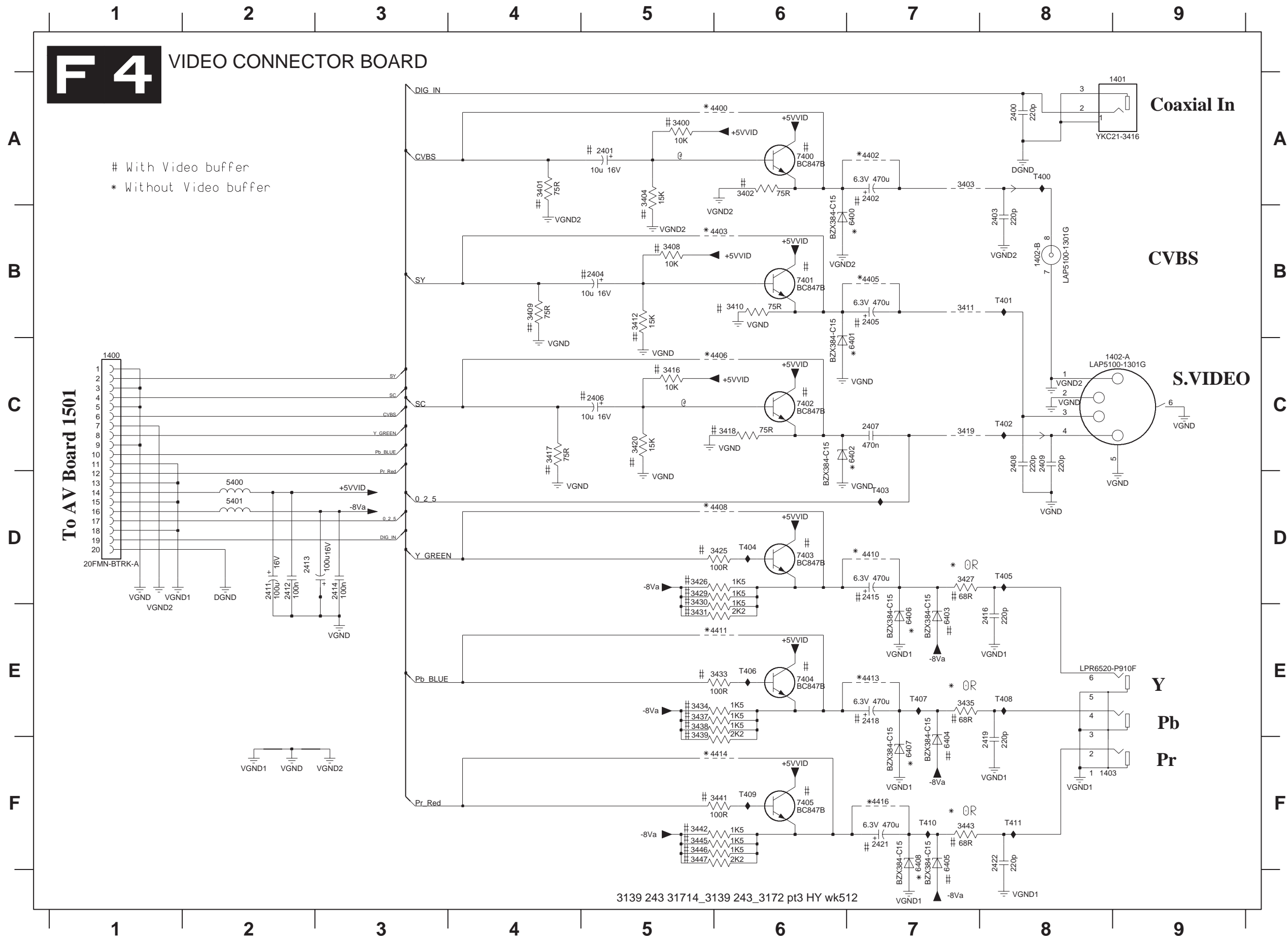

- 1400 C1
- 1401 A9
- 1402-A C9
- 1402-B B8
- 1403 F8
- 2400 A8
- 2401 A5
- 2402 A7
- 2403 B8
- 2404 B5
- 2405 B7
- 2406 C5
- 2407 C7
- 2408 C8
- 2409 C8
- 2411 D2
- 2412 D2
- 2413 D2
- 2414 D3
- 2415 D7
- 2416 E8
- 2418 E7
- 2419 F8
- 2421 F7
- 2422 F8
- 3400 A5
- 3401 A4
- 3402 A6
- 3403 A7
- 3404 A5
- 3408 B5
- 3409 B4
- 3410 B6
- 3411 B7
- 3412 B5
- 3416 C5
- 3417 C4
- 3418 C6
- 3419 C7
- 3420 C5
- 3425 D6
- 3426 D5
- 3427 D7
- 3429 D5
- 3430 E5
- 3431 E5
- 3433 E6
- 3434 E5
- 3435 E7
- 3437 E5
- 3438 E5
- 3439 F5
- 3441 F6
- 3442 F5
- 3443 F7
- 3445 F5
- 3446 F5
- 3447 F5
- 4400 A6
- 4402 A7
- 4403 B6
- 4405 B7
- 4406 C6
- 4408 D6
- 4410 D7
- 4411 E6
- 4413 E7
- 4414 F6
- 4416 F7
- 5400 D2
- 5401 D2
- 6400 B7
- 6401 C7
- 6402 C7
- 6403 E7
- 6404 F7
- 6405 F7
- 6406 E7
- 6407 F7
- 6408 F7
- 7400 A6
- 7401 B6
- 7402 C6
- 7403 D6
- 7404 E6
- 7405 F6
- T400 A8
- T401 B8
- T402 C8
- T403 D7
- T404 D6
- T405 D8
- T406 E6
- T407 E7
- T408 E8
- T409 F6
- T410 F7
- T411 F8

Video Connector Board - Component Layout

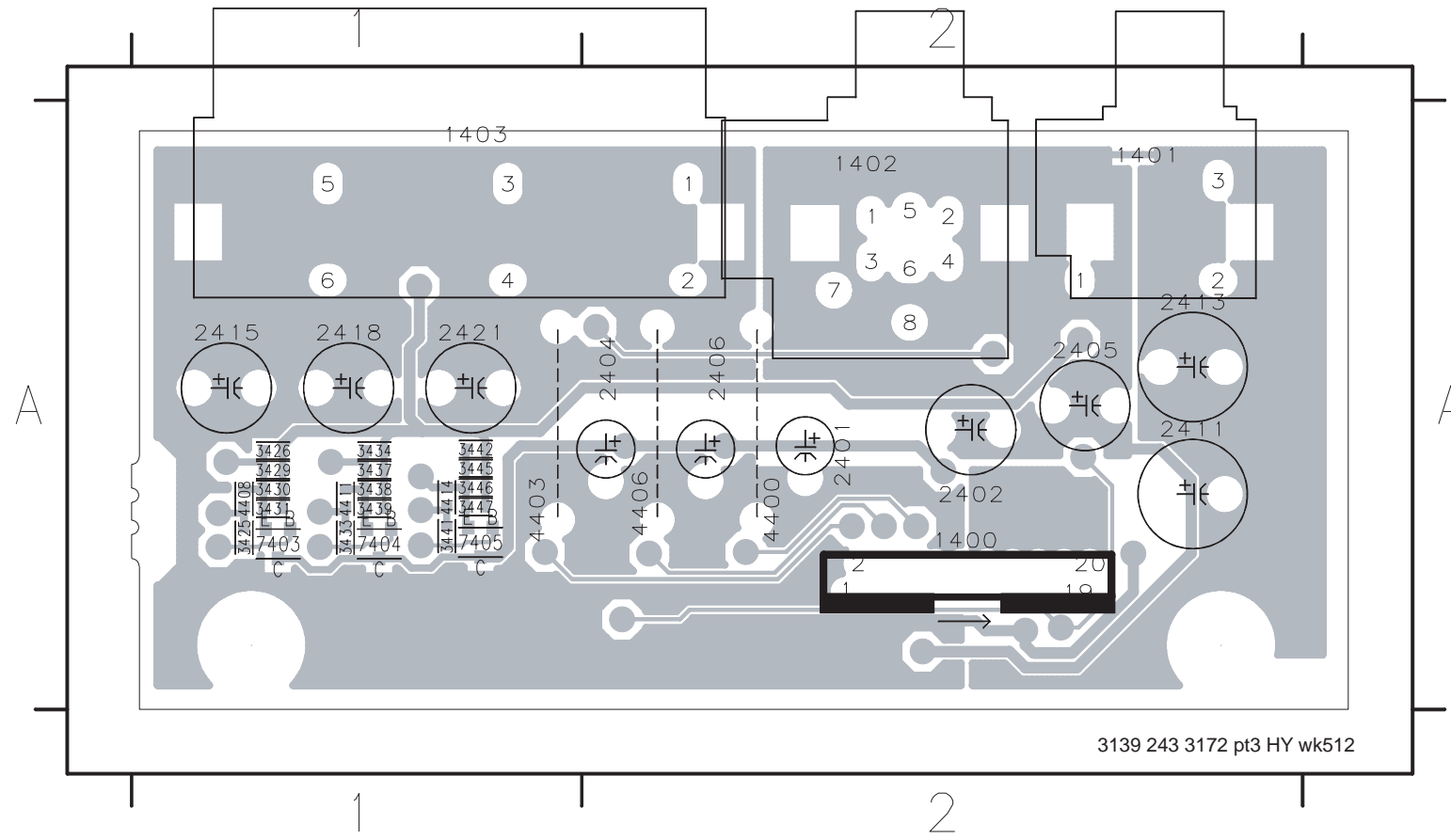

1400	A2	3446	A1
1401	A2	3447	A1
1402	A2	4400	A2
1403	A1	4403	A1
2401	A2	4406	A2
2402	A2	4408	A1
2404	A2	4411	A1
2405	A2	4414	A1
2406	A2	7403	A1
2411	A2	7404	A1
2413	A2	7405	A1
2415	A1		
2418	A1		
2421	A1		
3425	A1		
3426	A1		
3429	A1		
3430	A1		
3431	A1		
3433	A1		
3434	A1		
3437	A1		
3438	A1		
3439	A1		
3441	A1		
3442	A1		
3445	A1		

Video Connector Board - Chip Layout

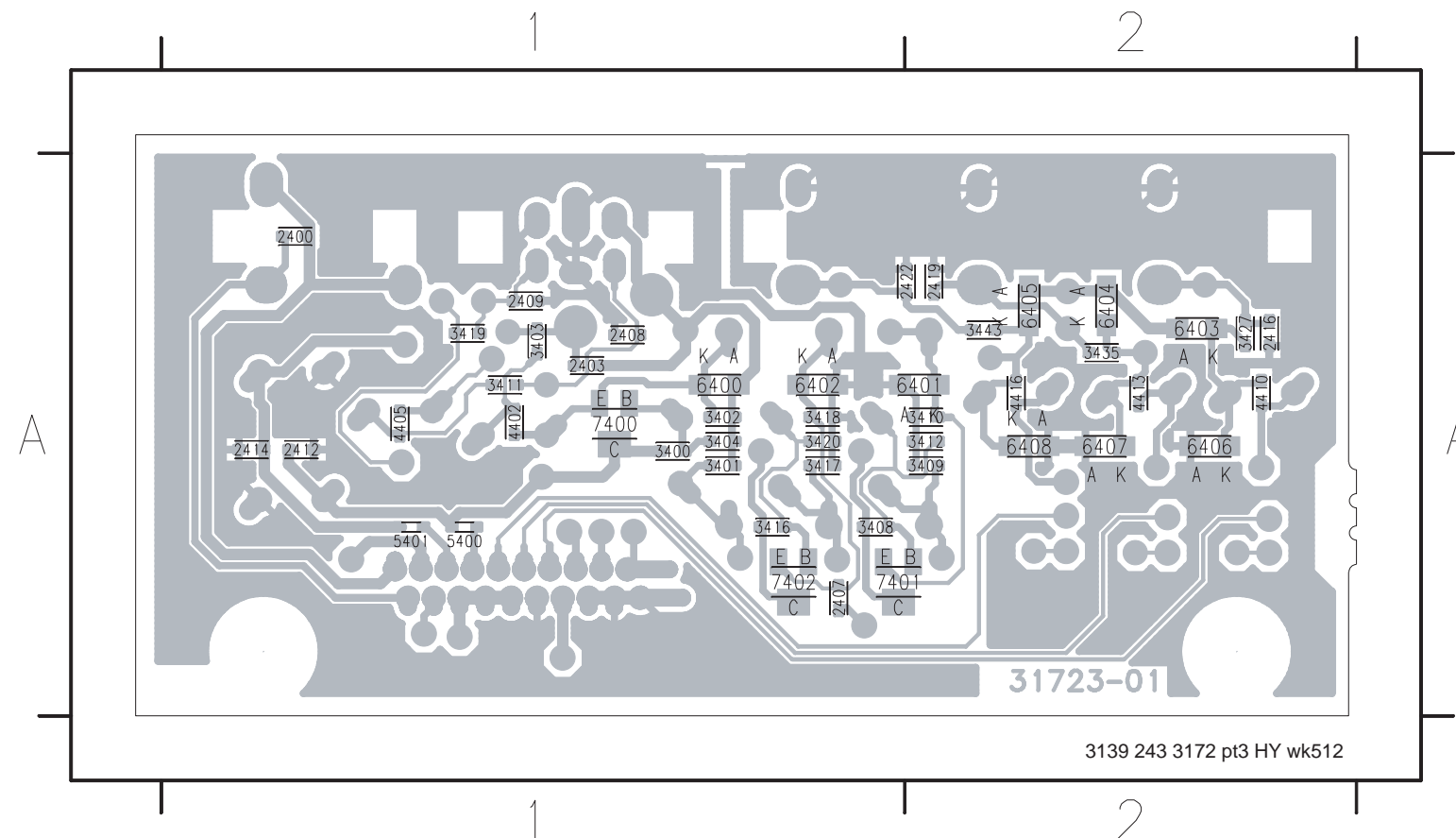

2400	A1	3443	A2
2403	A1	4402	A1
2407	A1	4405	A1
2408	A1	4410	A2
2409	A1	4413	A2
2412	A1	4416	A2
2414	A1	5400	A1
2416	A2	5401	A1
2419	A2	6400	A1
2422	A2	6401	A2
3400	A1	6402	A1
3401	A1	6403	A2
3402	A1	6404	A2
3403	A1	6405	A2
3404	A1	6406	A2
3408	A1	6407	A2
3409	A2	6408	A2
3410	A2	7400	A1
3411	A1	7401	A1
3412	A2	7402	A1
3416	A1		
3417	A1		
3418	A1		
3419	A1		
3420	A1		
3427	A2		
3435	A2		

7. AV Board AV Board - Top view layout

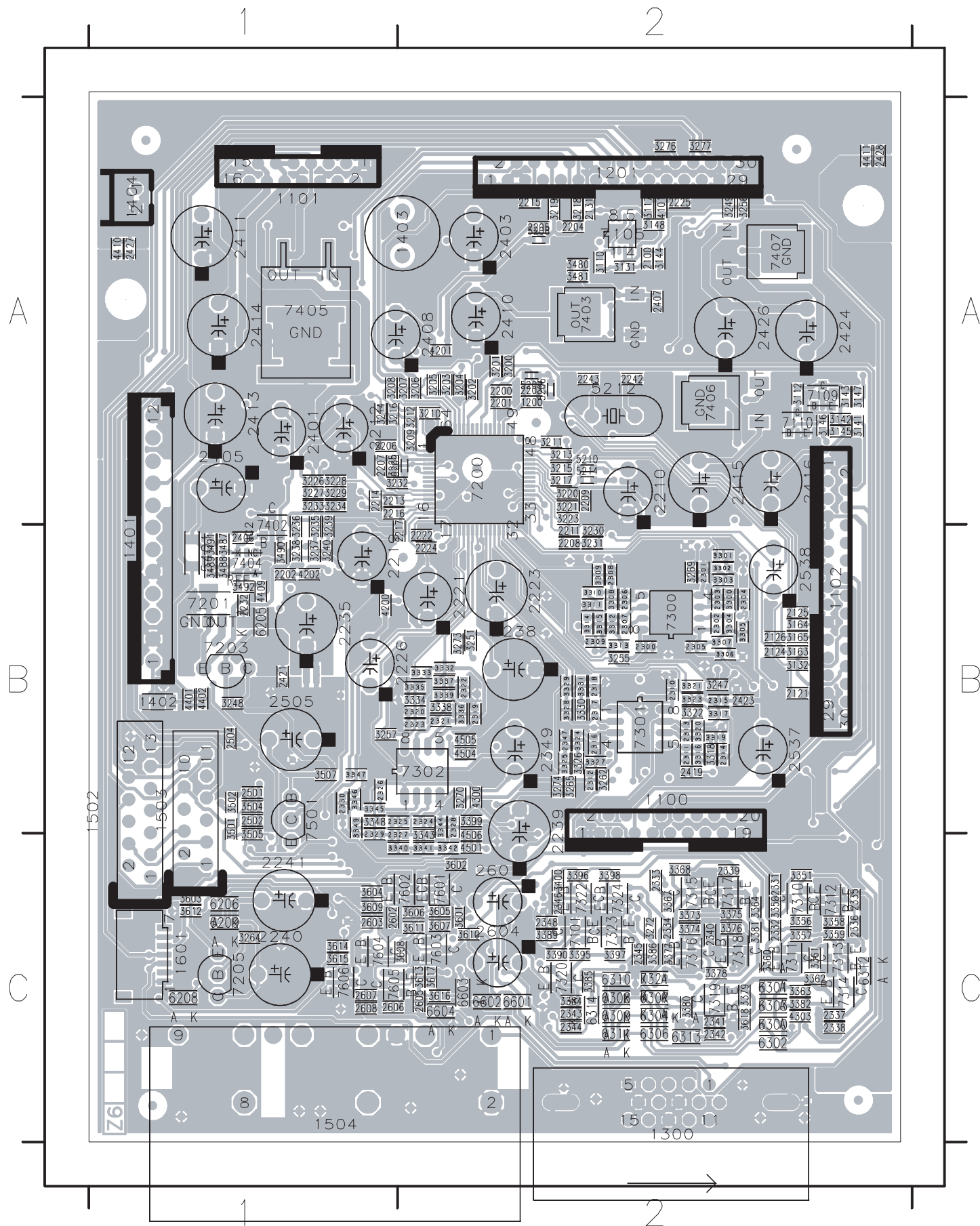

1100	B2	2308	B2	2501	B1	3233	A1	3336	B2	3601	C2	6603	C2
1101	A1	2309	B2	2502	B1	3234	A1	3337	B2	3602	C2	6604	C2
1102	B2	2310	B2	2504	B1	3235	B1	3338	B2	3603	C1	7101	C2
1200	A2	2311	B2	2505	B1	3236	B1	3339	B2	3604	C1	7105	A2
1201	A2	2312	B2	2537	B2	3237	B1	3340	C2	3605	C2	7109	A2
1300	C2	2313	B2	2538	B2	3238	B1	3341	C2	3606	C2	7110	A2
1401	B1	2314	B2	2601	C2	3239	B1	3342	C2	3607	C2	7200	A2
1402	B1	2315	B2	2602	C1	3240	B1	3343	C2	3608	C2	7201	B1
1403	A2	2316	B2	2603	C1	3247	B2	3344	B2	3609	C1	7203	B1
1404	A1	2317	B2	2604	C2	3248	B1	3345	B1	3610	C2	7205	C1
1502	B1	2318	B2	2605	C2	3249	A2	3346	B1	3611	C2	7300	B2
1503	B1	2319	B2	2606	C1	3251	B2	3347	B1	3612	C1	7301	B2
1504	C1	2320	B2	2607	C1	3255	B2	3348	B1	3613	C2	7302	B2
1601	C1	2321	B2	2608	C1	3256	A2	3349	B1	3614	C1	7310	C2
2100	A2	2322	B2	3110	A2	3257	B1	3350	C2	3615	C1	7311	C2
2121	B2	2323	B2	3112	A2	3262	B2	3351	C2	3616	C2	7312	C2
2124	B2	2324	B2	3117	A2	3264	C1	3356	C2	3617	C2	7313	C2
2125	B2	2325	B2	3131	A2	3265	B2	3357	C2	3618	C2	7314	C2
2126	B2	2326	B1	3132	B2	3269	B2	3358	C2	4101	A2	7315	C2
2131	A2	2327	C2	3141	A2	3270	B2	3359	C2	4200	B1	7316	C2
2200	A2	2328	B2	3142	A2	3272	C2	3360	C2	4201	A2	7317	C2
2201	A2	2329	C1	3143	A2	3273	B2	3361	C2	4202	B1	7318	C2
2202	B1	2330	B1	3144	A2	3274	B2	3362	C2	4300	B2	7319	C2
2203	A2	2331	C2	3145	A2	3276	A2	3363	C2	4303	C2	7320	C2
2204	A2	2332	C2	3146	A2	3277	A2	3364	C2	4401	B1	7321	C2
2205	A2	2333	C2	3147	A2	3300	B2	3367	C2	4402	B1	7322	C2
2206	A1	2334	C2	3148	A2	3301	B2	3368	C2	4409	B1	7323	C2
2207	A1	2335	C2	3163	B2	3302	B2	3373	C2	4410	A1	7324	C2
2208	B2	2336	C2	3164	B2	3303	B2	3374	C2	4411	A2	7402	B1
2209	A2	2337	C2	3165	B2	3304	B2	3375	C2	4501	C2	7403	A2
2210	A2	2338	C2	3200	A2	3305	B2	3376	C2	4504	B2	7404	B1
2211	B2	2339	C2	3201	A2	3306	B2	3377	C2	4505	B2	7405	A1
2212	A1	2340	C2	3202	A2	3307	B2	3378	C2	4506	C2	7406	A2
2213	A1	2341	C2	3203	A2	3308	B2	3379	C2	5206	A2	7407	A2
2214	A1	2342	C2	3204	A2	3309	B2	3380	C2	5207	A2	7501	B1
2215	A2	2343	C2	3205	A2	3310	B2	3381	C2	5208	A2	7601	C2
2216	A1	2344	C2	3206	A2	3311	B2	3382	C2	5209	A1	7602	C2
2217	B2	2345	C2	3207	A2	3312	B2	3384	C2	5210	A2	7603	C2
2219	B1	2346	C2	3208	A1	3313	B2	3385	C2	5212	A2	7604	C1
2221	B2	2347	B2	3209	A2	3314	B2	3386	C2	5214	A2	7605	C1
2222	B2	2348	C2	3210	A2	3315	B2	3389	C2	5401	B1	7606	C1
2223	B2	2349	B2	3211	A2	3316	B2	3390	C2	6205	B1		
2224	B2	2401	A1	3212	A2	3317	B2	3395	C2	6206	C1		
2225	A2	2403	A2	3213	A2	3318	B2	3396	C2	6208	C1		
2226	B2	2405	A1	3214	A1	3319	B2	3397	C2	6209	C1		
2232	B1	2406	B1	3215	A2	3320	B2	3398	C2	6300	C2		
2235	B1	2407	A2	3216	A1	3321	B2	3399	B2	6301	C2		
2238	B2	2408	A2	3217	A2	3322	B2	3400	C2	6302	C2		
2239	B2	2410	A2	3218	A2	3323	B2	3480	A2	6303	C2		
2240	C1	2411	A1	3219	A2	3324	B2	3481	A2	6304	C2		
2241	C1	2413	A1	3220	A2	3325	B2	3487	B1	6306	C1		
2242	A2	2414	A1	3221	A2	3326	B2	3488	B1	6307	C2		
2243	A2	2415	A2	3223	A2	3327	B2	3489	B1	6308	C2		
2300	B2	2416	A2	3225	A1	3328	B2	3490	B1	6309	C2		
2301	B2	2419	B2	3226	A1	3329	B2	3491	B1	6310	C2		
2302	B2	2421	B1	3227	A1	3330	B2	3492	B1	6311	C2		
2303	B2	2423	B2	3228	A1	3331	B2	3501	B1	6312	C2		
2304	B2	2424	A2	3229	A1	3332	B2	3502	B1	6313	C2		
2305	B2	2426	A2	3230	B2	3333	B2	3504	B1	6314	C2		
2306	B2	2427	A1	3231	B2	3334	B2	3505	C1	6601	C2		
2307	B2	2428	A2	3232	A1	3335	B2	3507	B1	6602	C2		

AV Board - Bottom view layout

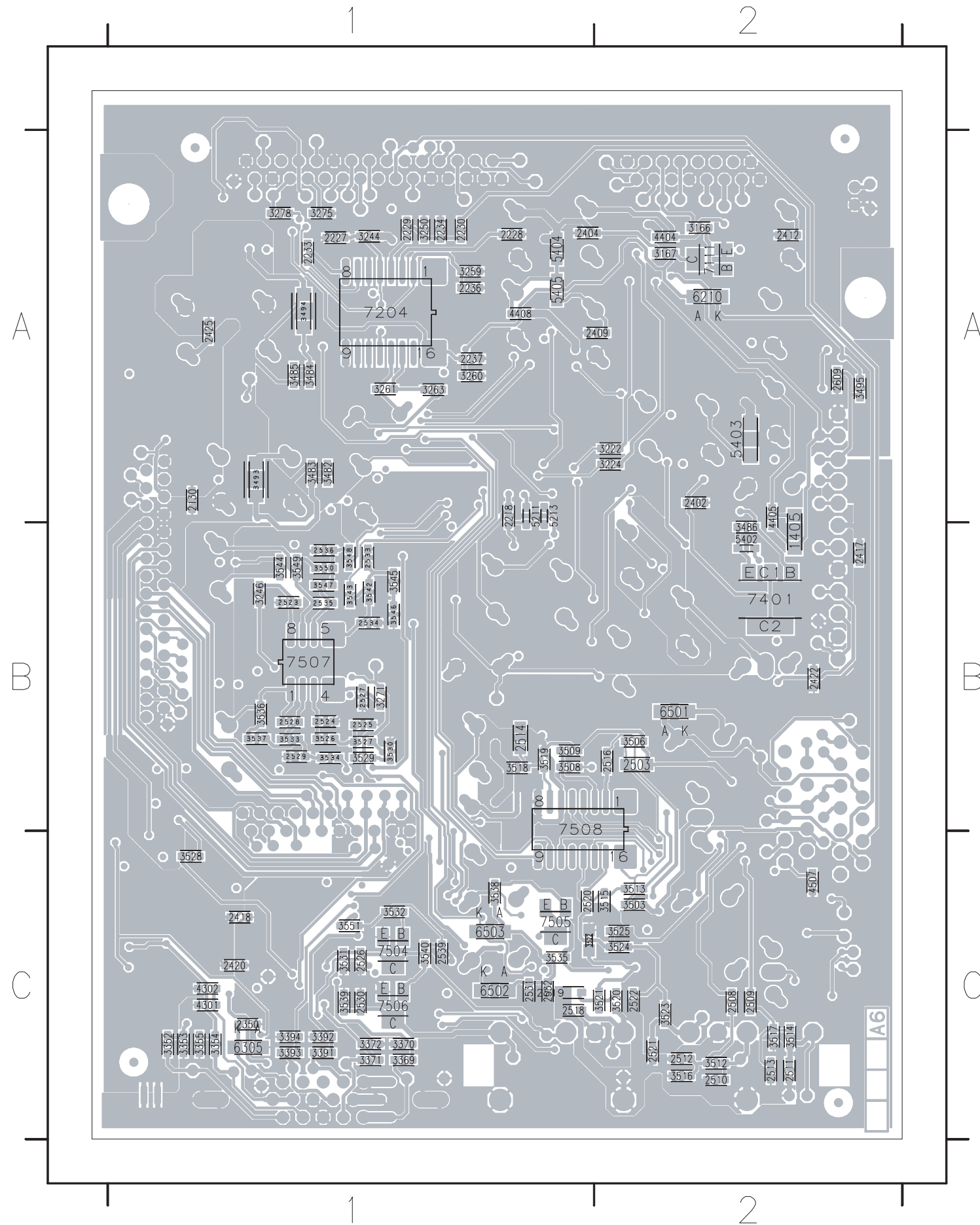

1405	B2	3263	A1	3546	B1
2130	A1	3271	B1	3547	B1
2218	A1	3275	A1	3548	B1
2227	A1	3278	A1	3549	B1
2228	A1	3352	C1	3550	B1
2229	A1	3353	C1	3551	C1
2230	A1	3354	C1	4301	C1
2233	A1	3355	C1	4302	C1
2234	A1	3369	C1	4404	A2
2236	A1	3370	C1	4405	A2
2237	A1	3371	C1	4408	A1
2350	C1	3372	C1	4507	C2
2402	A2	3391	C1	5211	A1
2404	A1	3392	C1	5213	A1
2409	A2	3393	C1	5402	B2
2412	A2	3394	C1	5403	A2
2417	B2	3482	A1	5404	A1
2418	C1	3483	A1	5405	A1
2420	C1	3484	A1	6210	A2
2422	B2	3485	A1	6305	C1
2425	A1	3486	B2	6501	B2
2503	B2	3493	A1	6502	C1
2508	C2	3494	A1	6503	C1
2509	C2	3495	A2	7111	A2
2510	C2	3503	C2	7204	A1
2511	C2	3506	B2	7401	B2
2512	C2	3508	B1	7504	C1
2513	C2	3509	B1	7505	C1
2514	B1	3512	C2	7506	C1
2516	B2	3513	C2	7507	B1
2518	C1	3514	C2	7508	B1
2519	C1	3515	C2		
2520	C1	3516	C2		
2521	C2	3517	C2		
2522	C2	3518	B1		
2523	B1	3519	B1		
2524	B1	3520	C2		
2525	B1	3521	C2		
2526	C1	3522	C1		
2527	B1	3523	C2		
2528	B1	3524	C2		
2529	B1	3525	C2		
2530	C1	3526	B1		
2531	C1	3527	B1		
2532	C1	3528	C1		
2533	B1	3529	B1		
2534	B1	3530	B1		
2535	B1	3531	C1		
2536	B1	3532	C1		
2539	C1	3533	B1		
2609	A2	3534	B1		
3166	A2	3535	C1		
3167	A2	3536	B1		
3222	A2	3537	B1		
3224	A2	3538	C1		
3244	A1	3539	C1		
3246	B1	3540	C1		
3250	A1	3542	B1		
3259	A1	3543	B1		
3260	A1	3544	B1		
3261	A1	3545	B1		

AV Board - Circuit Diagram (Part 1)

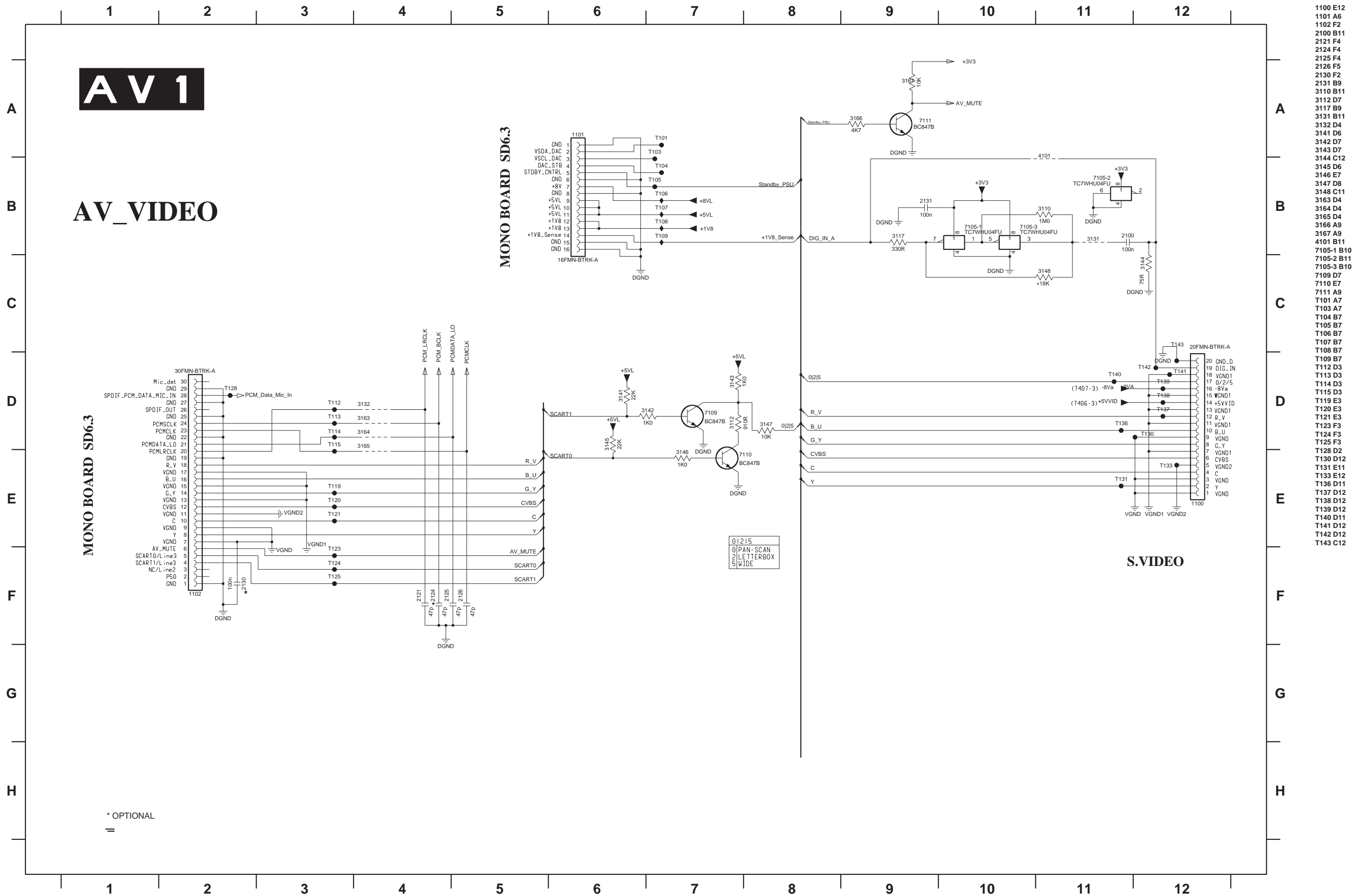

- 1100 E12
- 1101 A6
- 1102 F2
- 2100 B11
- 2121 F4
- 2124 F4
- 2125 F4
- 2126 F5
- 2130 F2
- 2131 B9
- 3110 B11
- 3112 D7
- 3117 B9
- 3131 B11
- 3132 D4
- 3141 D6
- 3142 D7
- 3143 D7
- 3144 C12
- 3145 D6
- 3146 E7
- 3147 D8
- 3148 C11
- 3163 D4
- 3164 D4
- 3165 D4
- 3166 A9
- 3167 A9
- 4101 B11
- 7105-1 B10
- 7105-2 B11
- 7105-3 B10
- 7109 D7
- 7110 E7
- 7111 A9
- T101 A7
- T103 A7
- T104 B7
- T105 B7
- T106 B7
- T107 B7
- T108 B7
- T109 B7
- T112 B3
- T113 D3
- T114 D3
- T115 D3
- T119 E3
- T120 E3
- T121 E3
- T123 F3
- T124 F3
- T125 F3
- T128 D2
- T130 D12
- T131 E11
- T133 E12
- T136 D11
- T137 D12
- T138 D12
- T139 D12
- T140 D11
- T141 D12
- T142 D12
- T143 C12

AV Board - Circuit Diagram (Part 2)

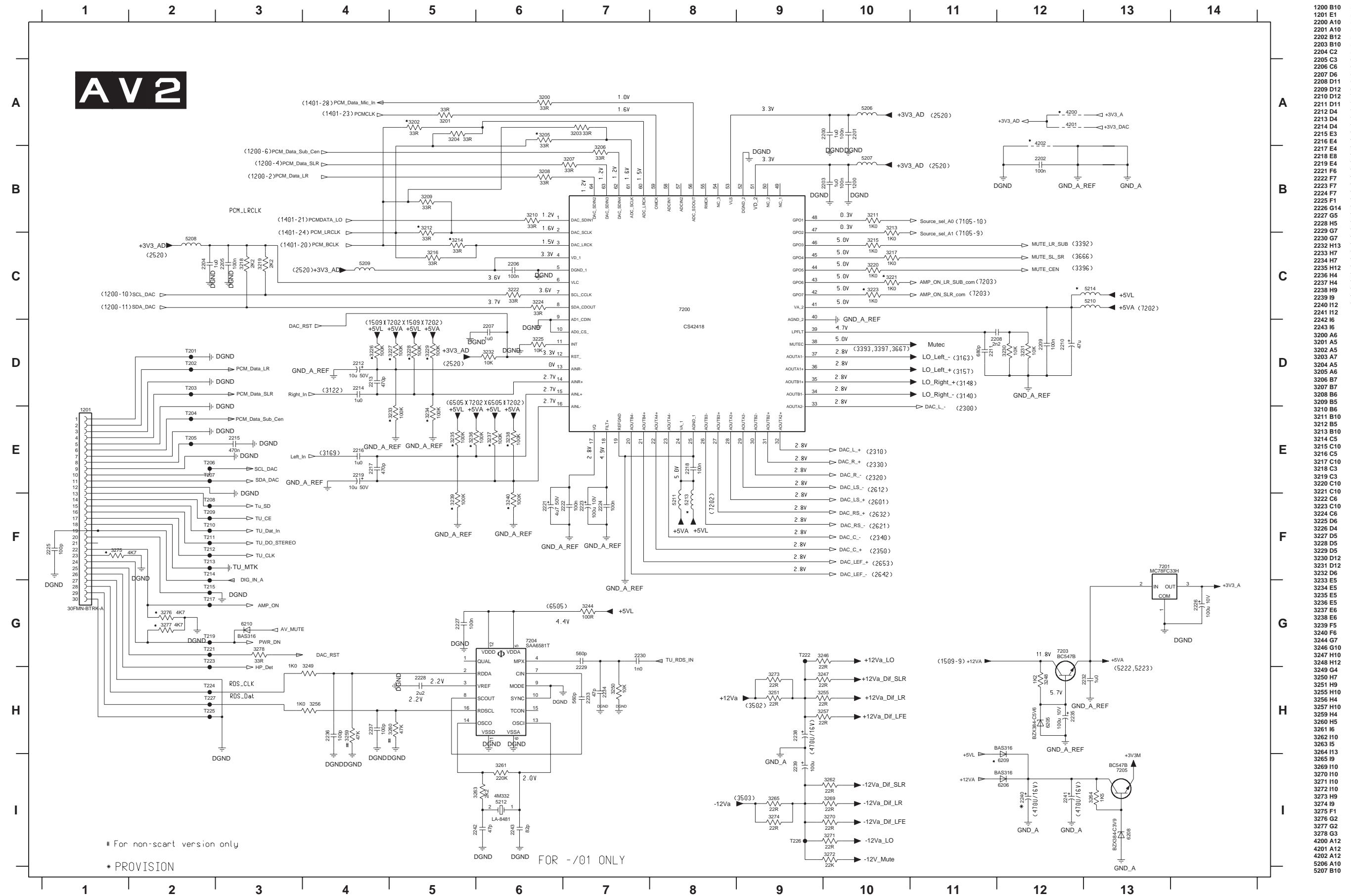

AV Board - Circuit Diagram (Part 3)

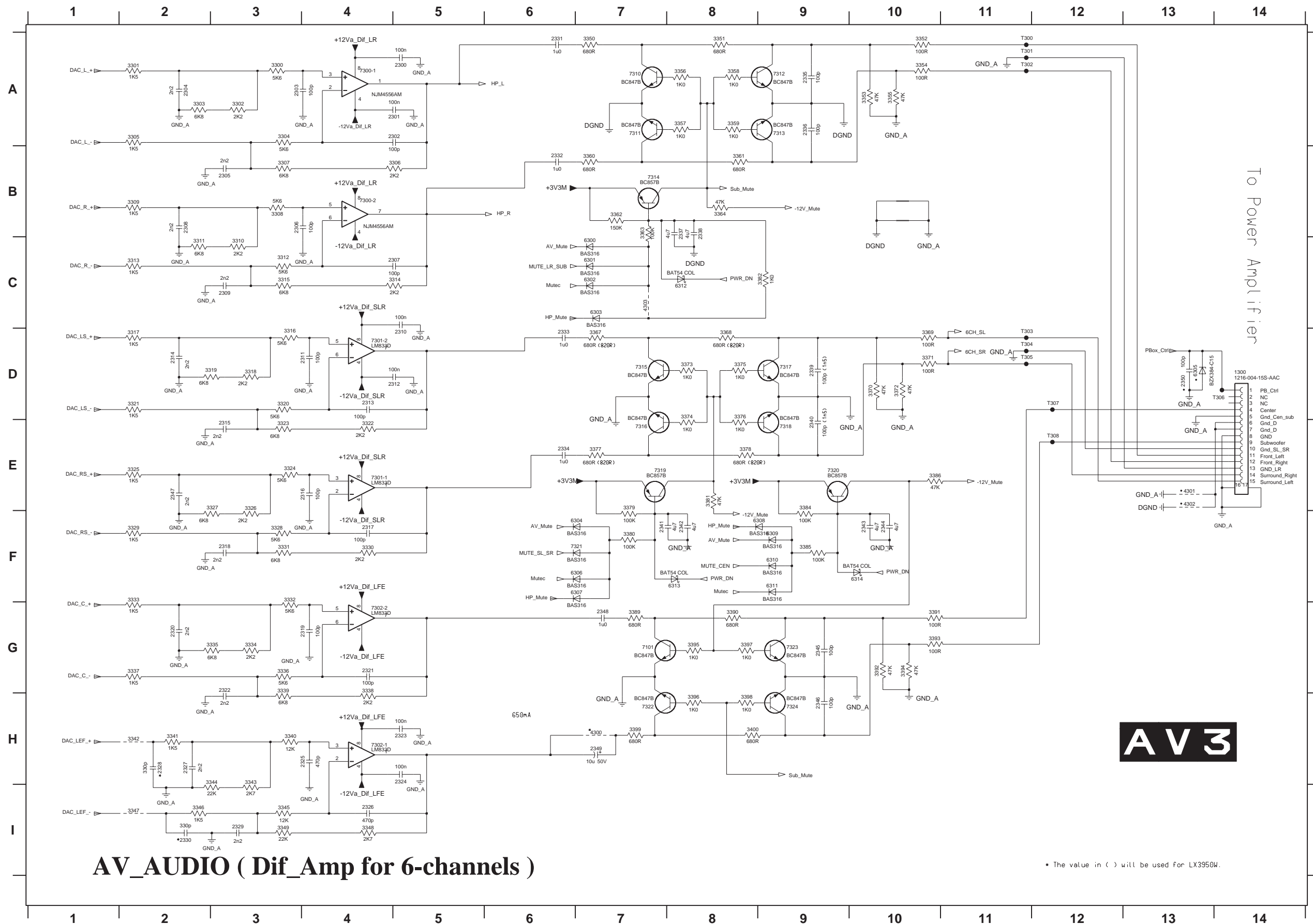

AV_AUDIO (Dif_Amp for 6-channels)

* The value in () will be used for LX3950W.

1300 D14	3363 B7
2300 A5	3364 B8
2301 A5	3367 D7
2302 A5	3368 D8
2303 A3	3369 D10
2304 A2	3370 D10
2305 B3	3371 D10
2306 B3	3372 D10
2307 C5	3373 D8
2308 B2	3374 D8
2309 C3	3375 D8
2310 D5	3376 D8
2311 D4	3377 E7
2312 D5	3378 E8
2313 D4	3379 E7
2314 D2	3380 F7
2315 E3	3381 E8
2316 E4	3382 C9
2317 F4	3384 E9
2318 F3	3385 F9
2319 G4	3386 E10
2320 G2	3389 G7
2321 G4	3390 G8
2322 G3	3391 G10
2323 H5	3392 G10
2324 H5	3393 G10
2325 H4	3394 G10
2326 I4	3395 G8
2327 H2	3396 H8
2328 H2	3397 G8
2329 I3	3398 H8
2330 I2	3399 H7
2331 A6	3400 H8
2332 B6	4300 H7
2333 D6	4301 E13
2334 E6	4302 E13
2335 A9	4303 C7
2336 A9	6300 C7
2337 B8	6301 C7
2338 B8	6302 C7
2339 D9	6303 C7
2340 E9	6304 F7
2341 F7	6305 D13
2342 F8	6306 F7
2343 F10	6307 F7
2344 F10	6308 F9
2345 G9	6309 F9
2346 H9	6310 F9
2347 E2	6311 F9
2348 G7	6312 C8
2349 H7	6313 F8
2350 D13	6314 F10
3300 A3	7101 G7
3301 A2	7300-1 A4
3302 A3	7300-2 B4
3303 A2	7301-1 E4
3304 A3	7301-2 D4
3305 A2	7302-1 H4
3306 B5	7302-2 G4
3307 B3	7310 A7
3308 B3	7311 A7
3309 B2	7312 A9
3310 C3	7313 A9
3311 C2	7314 B7
3312 C3	7315 D7
3313 C2	7316 E7
3314 C5	7317 D9
3315 C3	7318 E9
3316 D3	7319 E7
3317 D2	7320 E9
3318 D3	7321 F7
3319 D3	7322 H7
3320 D3	7323 G9
3321 D2	7324 H9
3322 E4	7300 A11
3323 E3	7301 A11
3324 E2	7302 A11
3325 E2	7303 D11
3326 E3	7304 D11
3327 E3	7305 D11
3328 F3	7306 D14
3329 F2	7307 D12
3330 F4	7308 E12
3331 F3	
3332 F3	
3333 F2	
3334 G3	
3335 G3	
3336 G3	
3337 G2	
3338 G4	
3339 G3	
3340 H3	
3341 H2	
3342 H2	
3343 H3	
3344 H3	
3345 I3	
3346 I2	
3347 I2	
3348 I4	
3349 I3	
3350 A7	
3351 A8	
3352 A10	
3353 A10	
3354 A10	
3355 A10	
3356 A8	
3357 A8	
3358 A8	
3359 A8	
3360 B7	
3361 B8	
3362 B7	

AV Board - Circuit Diagram (Part 4)

AV 4 AV_VIDEO (Supply Distribution)

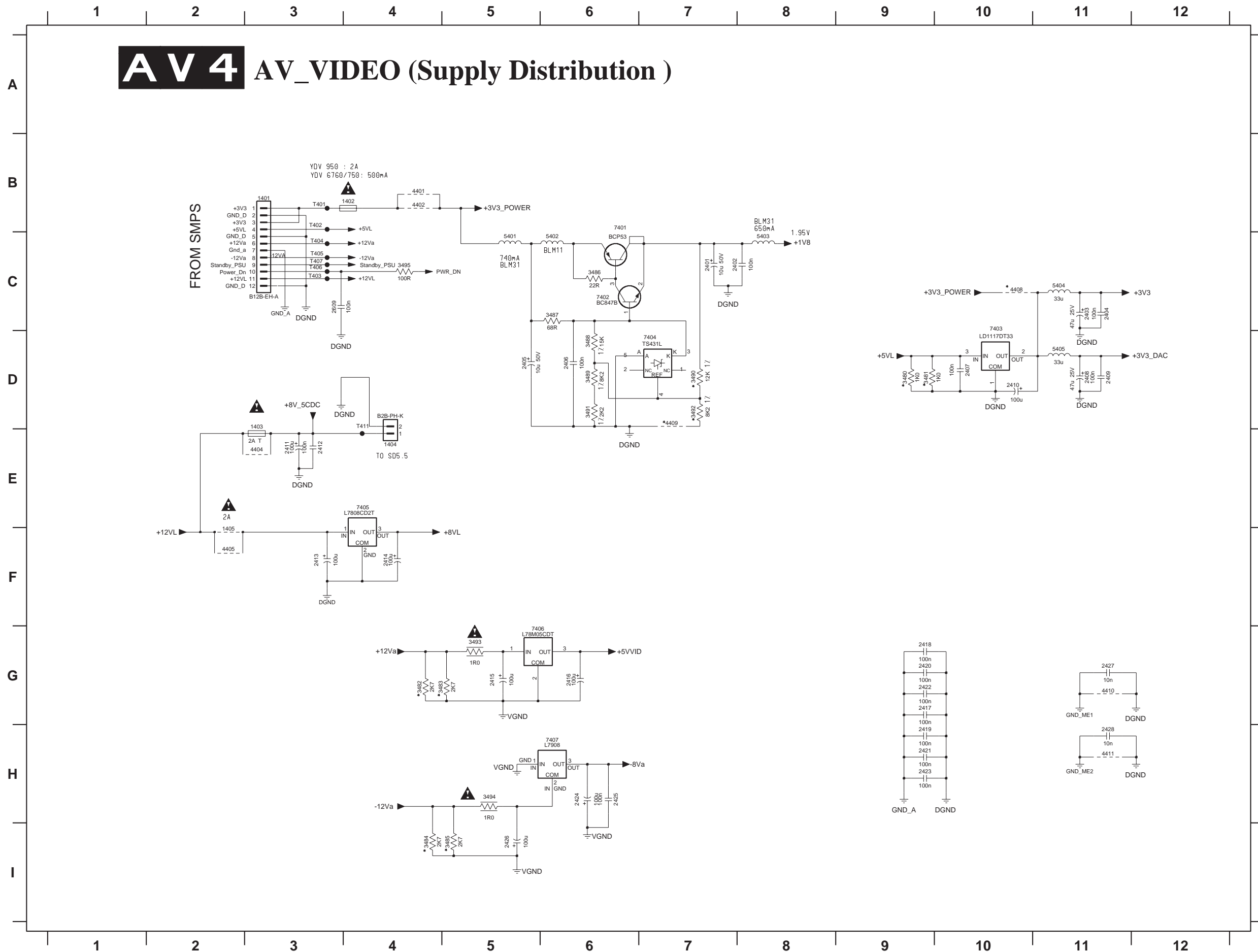

- 1401 B3
- 1402 B4
- 1403 E3
- 1404 E4
- 1405 F2
- 2401 C7
- 2402 C7
- 2403 C11
- 2404 C11
- 2405 D5
- 2406 D6
- 2407 D10
- 2408 D11
- 2409 D11
- 2410 D10
- 2411 E3
- 2412 E3
- 2413 F3
- 2414 F4
- 2415 G5
- 2416 G6
- 2417 G9
- 2418 G9
- 2419 H9
- 2420 G9
- 2421 H9
- 2422 G9
- 2423 H9
- 2424 H6
- 2425 H6
- 2426 I5
- 2427 G11
- 2428 H11
- 2609 C3
- 3480 D9
- 3481 D9
- 3482 G4
- 3483 G5
- 3484 I4
- 3485 I5
- 3486 C6
- 3487 C6
- 3488 D6
- 3489 D6
- 3490 D7
- 3491 D6
- 3492 D7
- 3493 G5
- 3494 H5
- 3495 C4
- 4401 B4
- 4402 B4
- 4403 E3
- 4404 E3
- 4405 F2
- 4406 C10
- 4409 D7
- 4410 G11
- 4411 H11
- 5401 C5
- 5402 C6
- 5403 C8
- 5404 C11
- 5405 D11
- 7401 B6
- 7402 C6
- 7403 D10
- 7404 D7
- 7405 E4
- 7406 G5
- 7407 H6
- T401 B3
- T402 B3
- T403 C3
- T404 C3
- T405 C3
- T406 C3
- T407 C3
- T411 D4

AV Board - Circuit Diagram (Part 5)

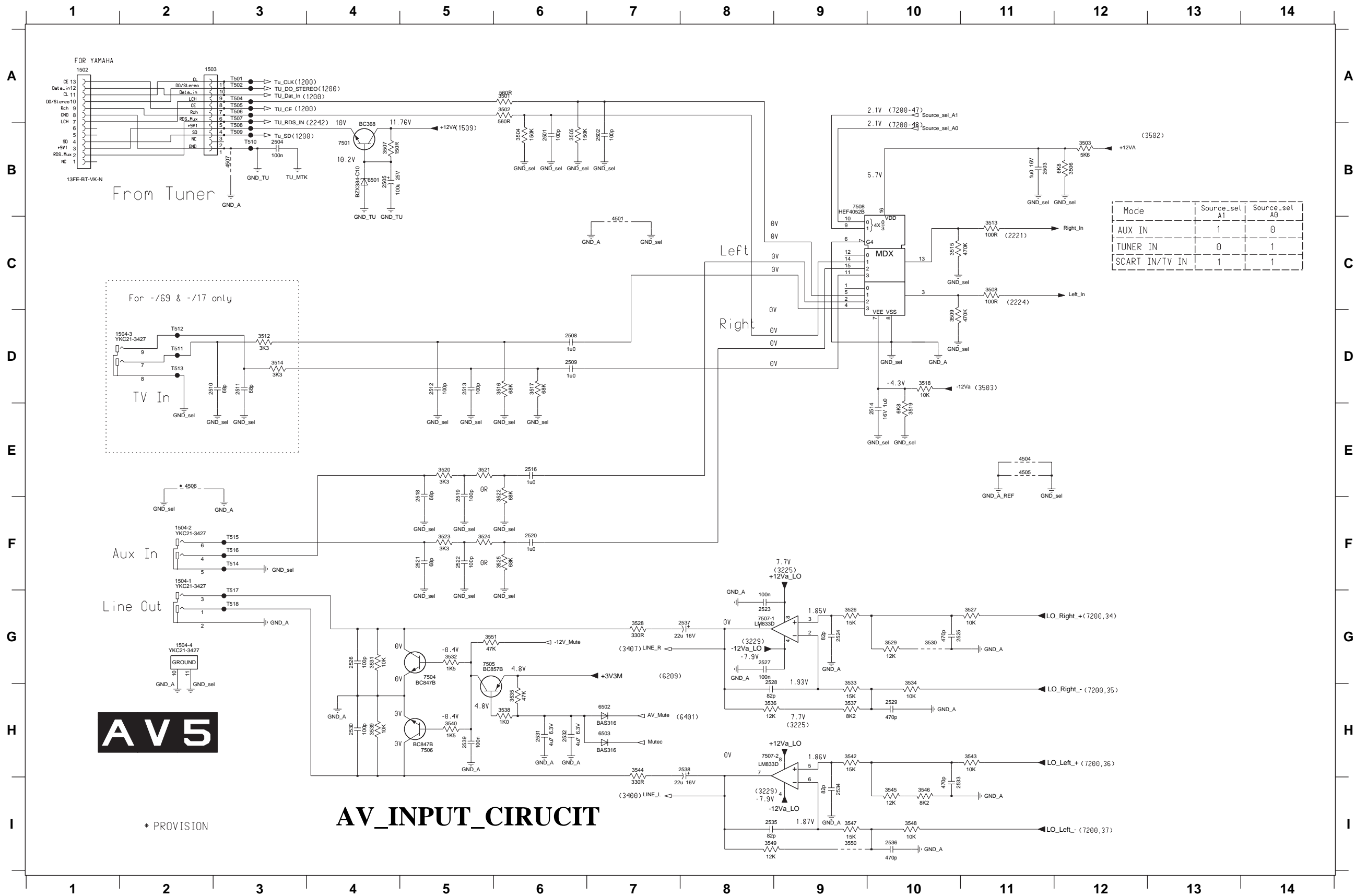

- 1502 A1
- 1503 A2
- 1504-1 F2
- 1504-2 F2
- 1504-3 D2
- 1504-4 G2
- 2501 B6
- 2502 B7
- 2503 B11
- 2504 B3
- 2505 B4
- 2508 D6
- 2509 D6
- 2510 D2
- 2511 D3
- 2512 D5
- 2513 D5
- 2514 E10
- 2516 E6
- 2518 E5
- 2519 E5
- 2520 F6
- 2521 F5
- 2522 F5
- 2523 G8
- 2524 G9
- 2525 G10
- 2526 G4
- 2527 G8
- 2528 H8
- 2529 H10
- 2530 H4
- 2531 H6
- 2532 H6
- 2533 H10
- 2534 I9
- 2535 I8
- 2536 I10
- 2537 G8
- 2538 H8
- 2539 H5
- 3501 A6
- 3502 A6
- 3503 B12
- 3504 B6
- 3505 B6
- 3506 B12
- 3507 B4
- 3508 C11
- 3509 D10
- 3512 D3
- 3513 C11
- 3514 D3
- 3515 C10
- 3516 D6
- 3517 D6
- 3518 D10
- 3519 E10
- 3520 E5
- 3521 E5
- 3522 E6
- 3523 F5
- 3524 F5
- 3525 F6
- 3526 G9
- 3527 G11
- 3528 G7
- 3529 G10
- 3530 G10
- 3531 G4
- 3532 G5
- 3533 H9
- 3534 H10
- 3535 H6
- 3536 H8
- 3537 H9
- 3538 H6
- 3539 H4
- 3540 H5
- 3542 H9
- 3543 H11
- 3544 H7
- 3545 I10
- 3546 I10
- 3547 I9
- 3548 I10
- 3549 I8
- 3550 I9
- 3551 G5
- 4501 C7
- 4504 E11
- 4505 E11
- 4506 E2
- 4507 B3
- 6501 B4
- 6502 H7
- 6503 H7
- 7501 B4
- 7504 G5
- 7505 G5
- 7506 H5
- 7507-1 G9
- 7507-2 H9
- 7508 B9
- T501 A3
- T502 A3
- T504 A3
- T505 A3
- T506 A3
- T507 A3
- T508 B3
- T509 B3
- T510 B3
- T511 D2
- T512 D2
- T513 D2
- T514 F3
- T515 F3
- T516 F3
- T517 F3
- T518 G3

AV Board - Circuit Diagram (Part 6)

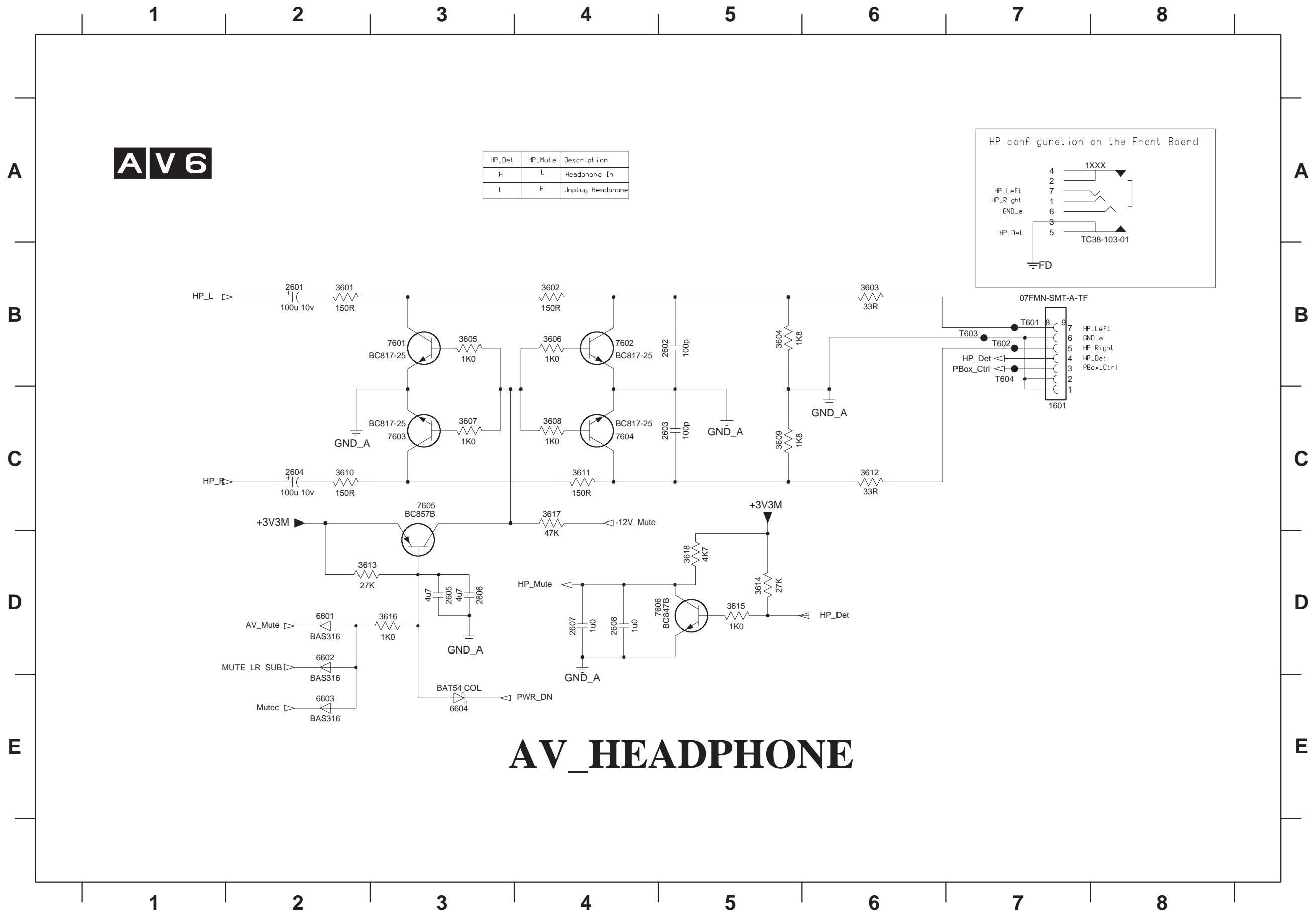

- 1601 C7
- 2601 B2
- 2602 B5
- 2603 C5
- 2604 C2
- 2605 D3
- 2606 D3
- 2607 D4
- 2608 D4
- 3601 B2
- 3602 B4
- 3603 B6
- 3604 B5
- 3605 B3
- 3606 B4
- 3607 C3
- 3608 C4
- 3609 C5
- 3610 C2
- 3611 C4
- 3612 C6
- 3613 D2
- 3614 D5
- 3615 D5
- 3616 D3
- 3617 C4
- 3618 D5
- 6601 D2
- 6602 D2
- 6603 E2
- 6604 E3
- 7601 B3
- 7602 B4
- 7603 C3
- 7604 C4
- 7605 C3
- 7606 D5
- T601 B7
- T602 B7
- T603 B7
- T604 B7

Power Supply Unit - Circuit Diagram (Part 1)

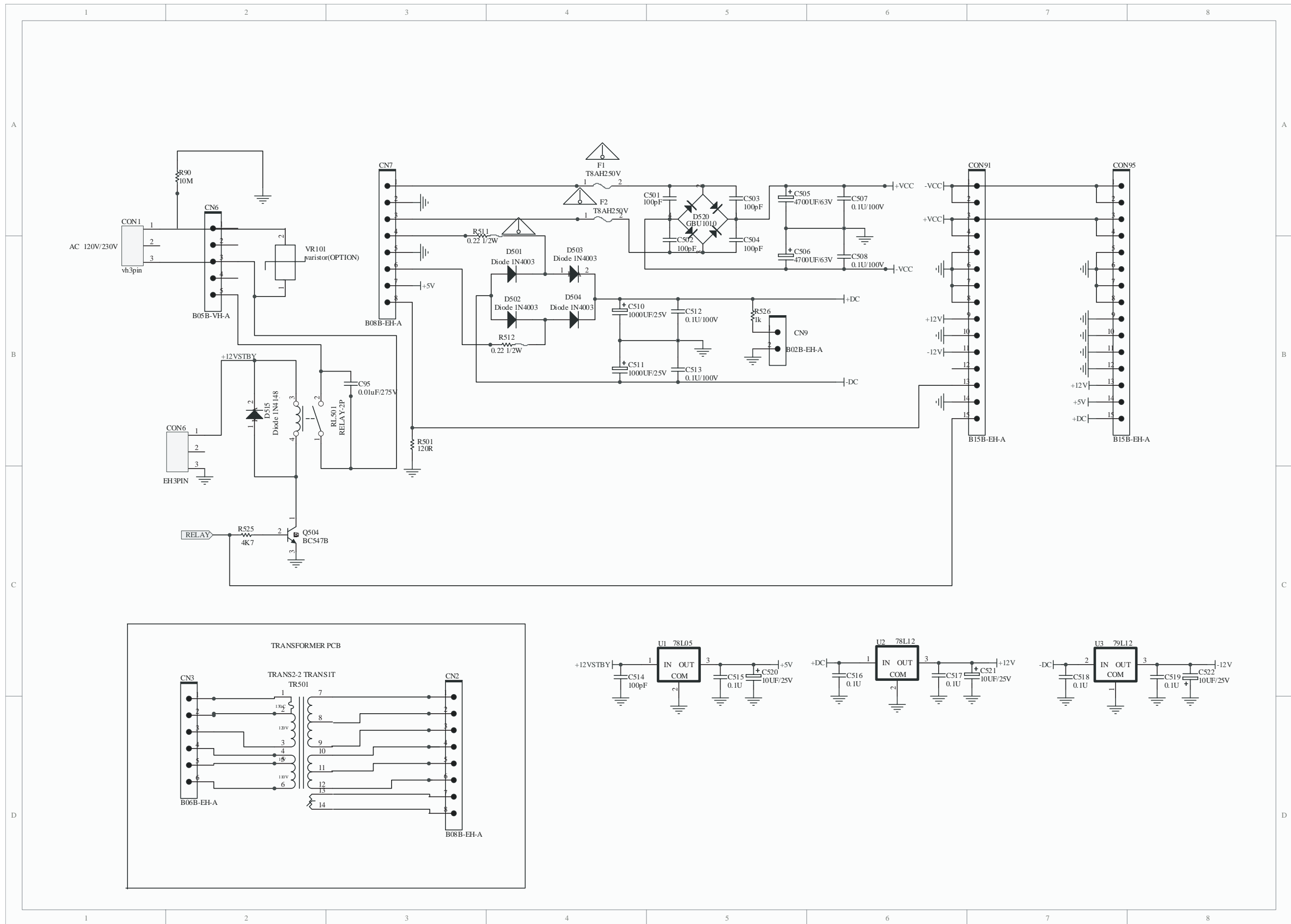

Power Supply Unit - Circuit Diagram (Part 2)

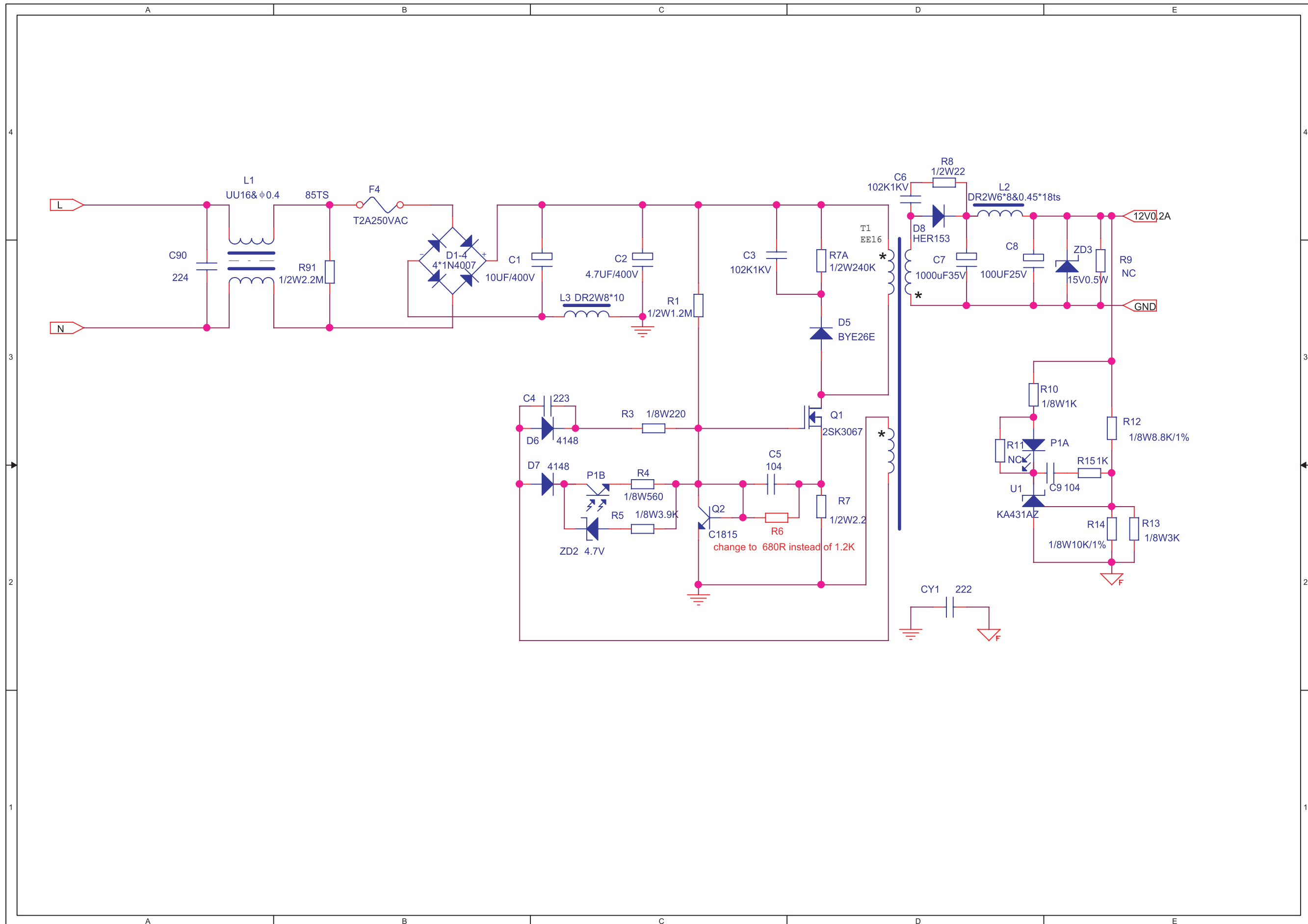

Interface - Top view layout

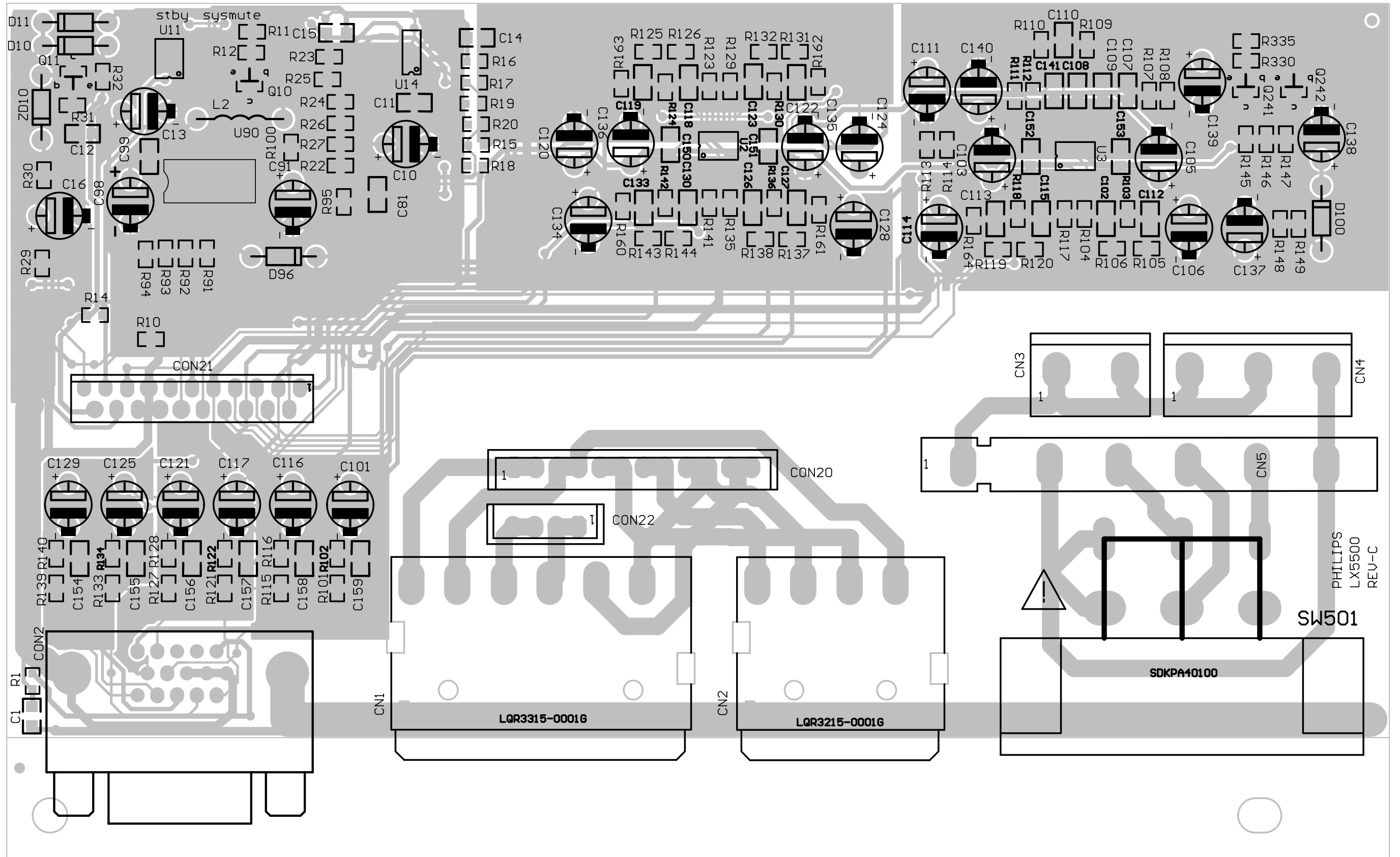

Interface - Circuit Diagram (Part 1)

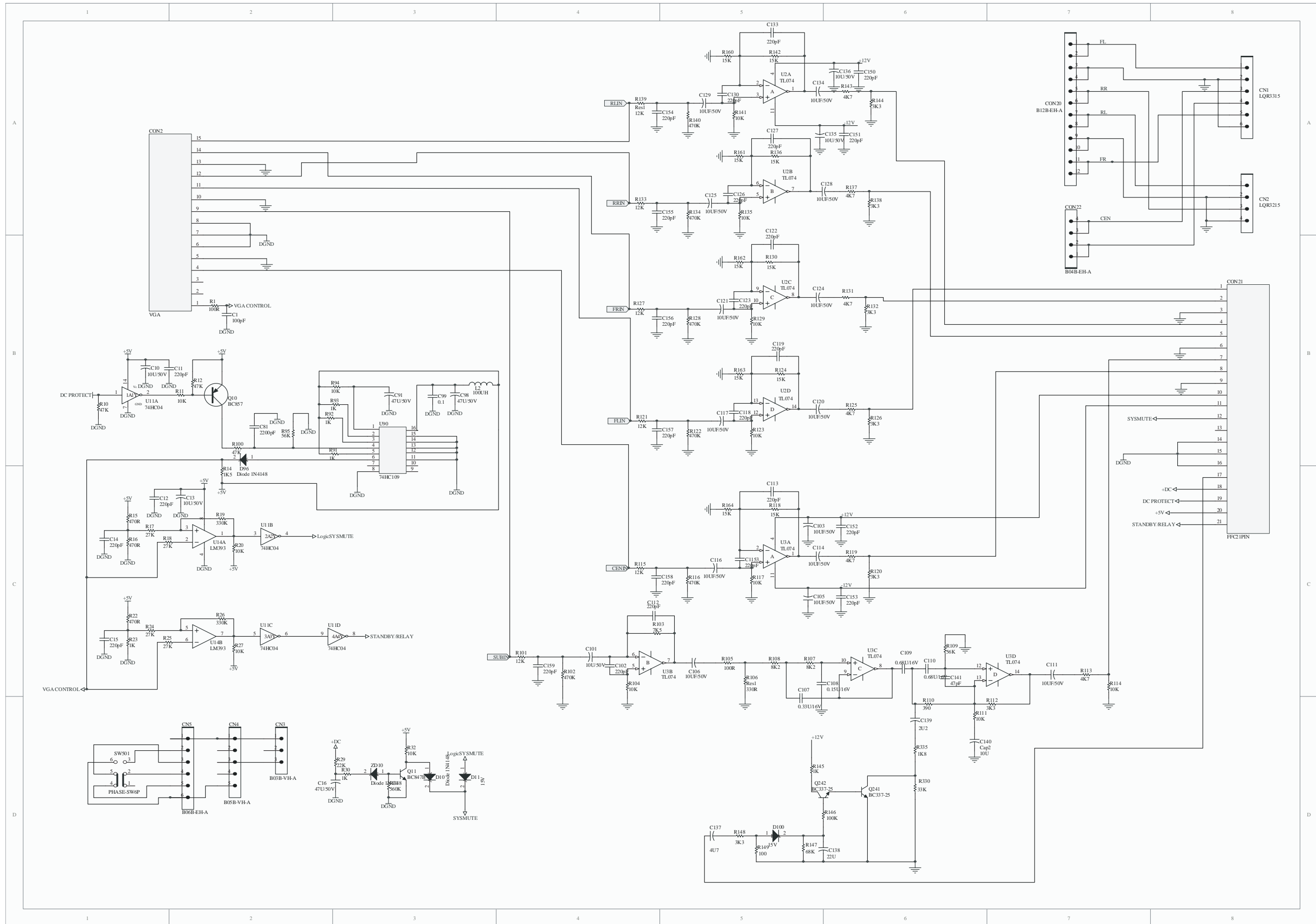

Main Amplifier - Top view layout

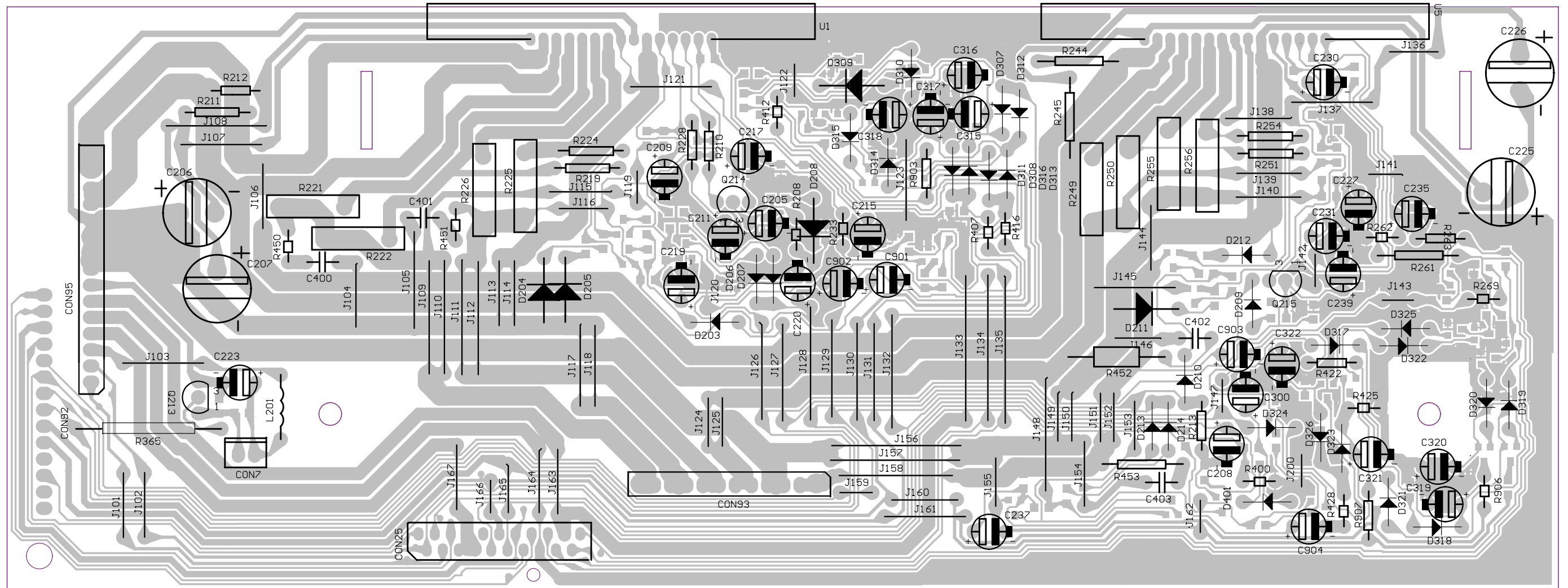

Main Amplifer - Bottom view layout

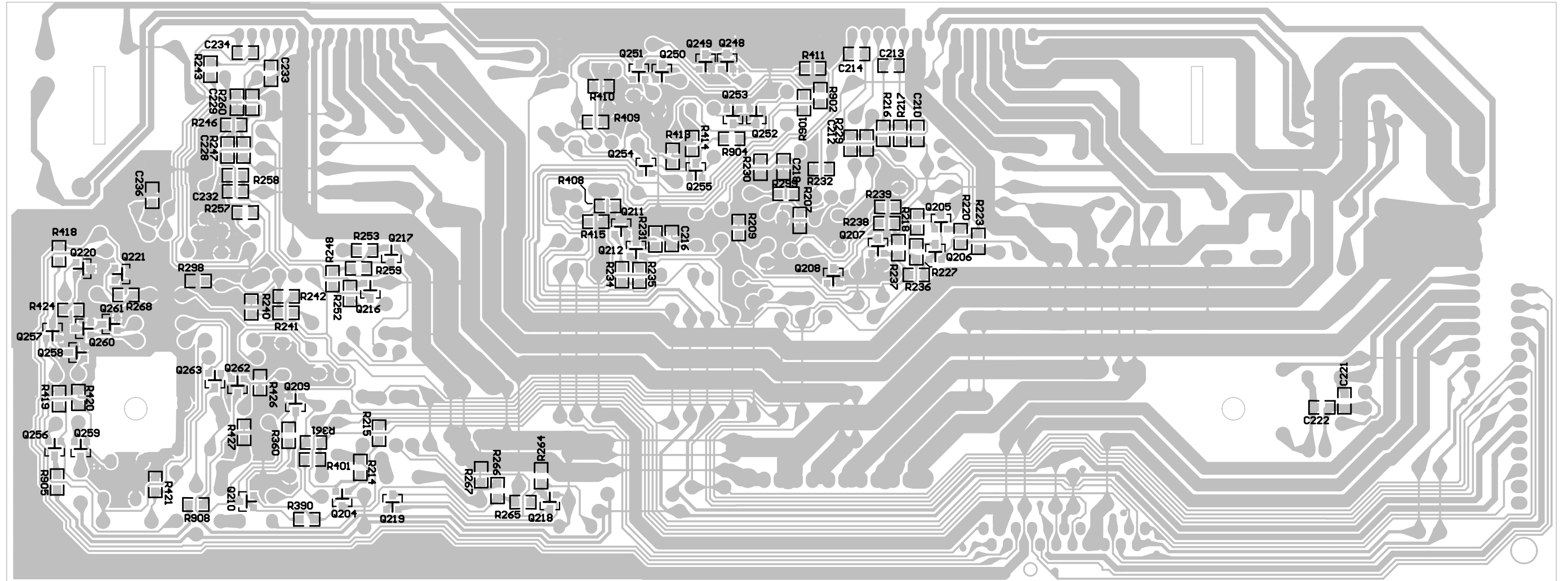

Connector schematic

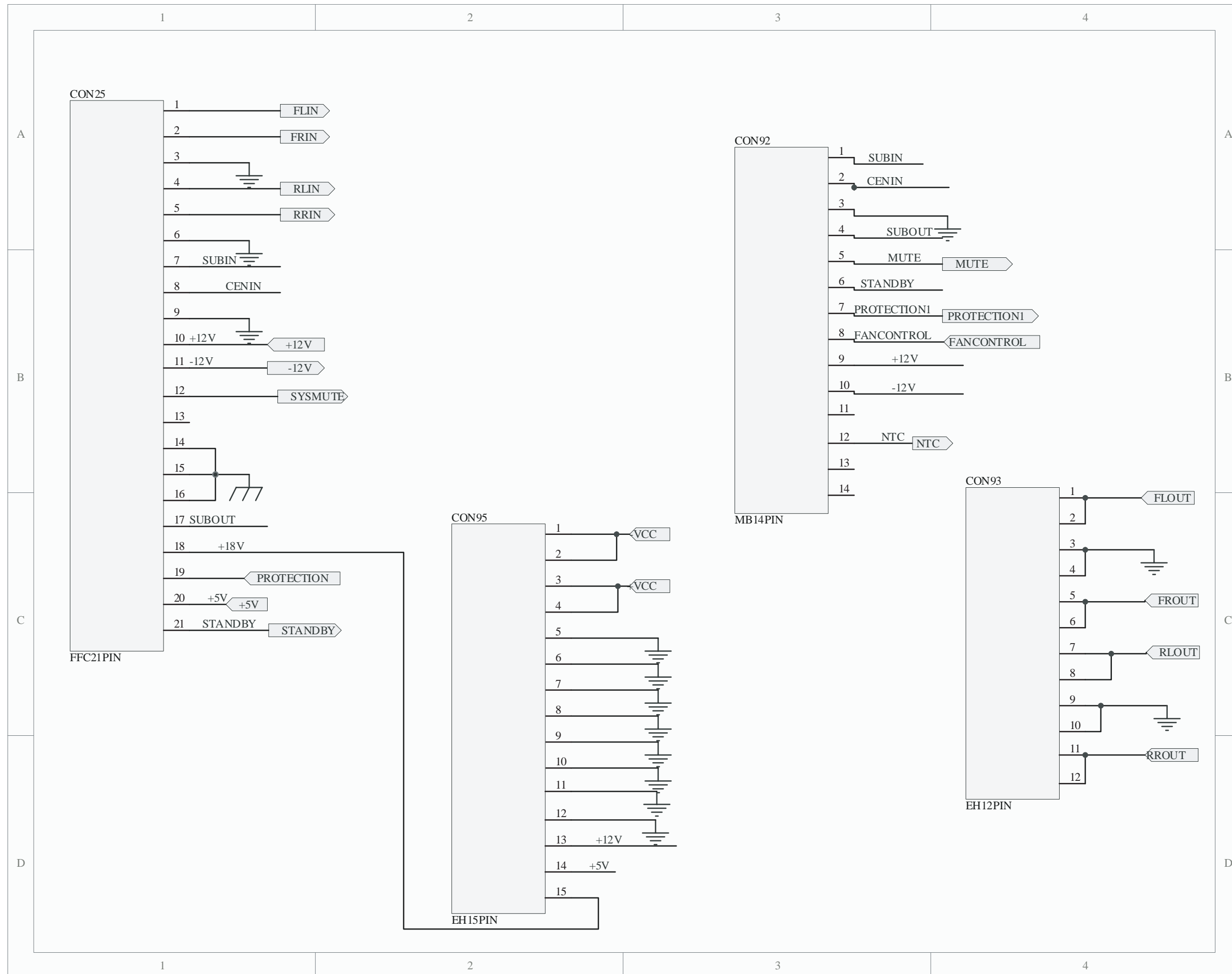

FR+SURROUND amplifier schematic

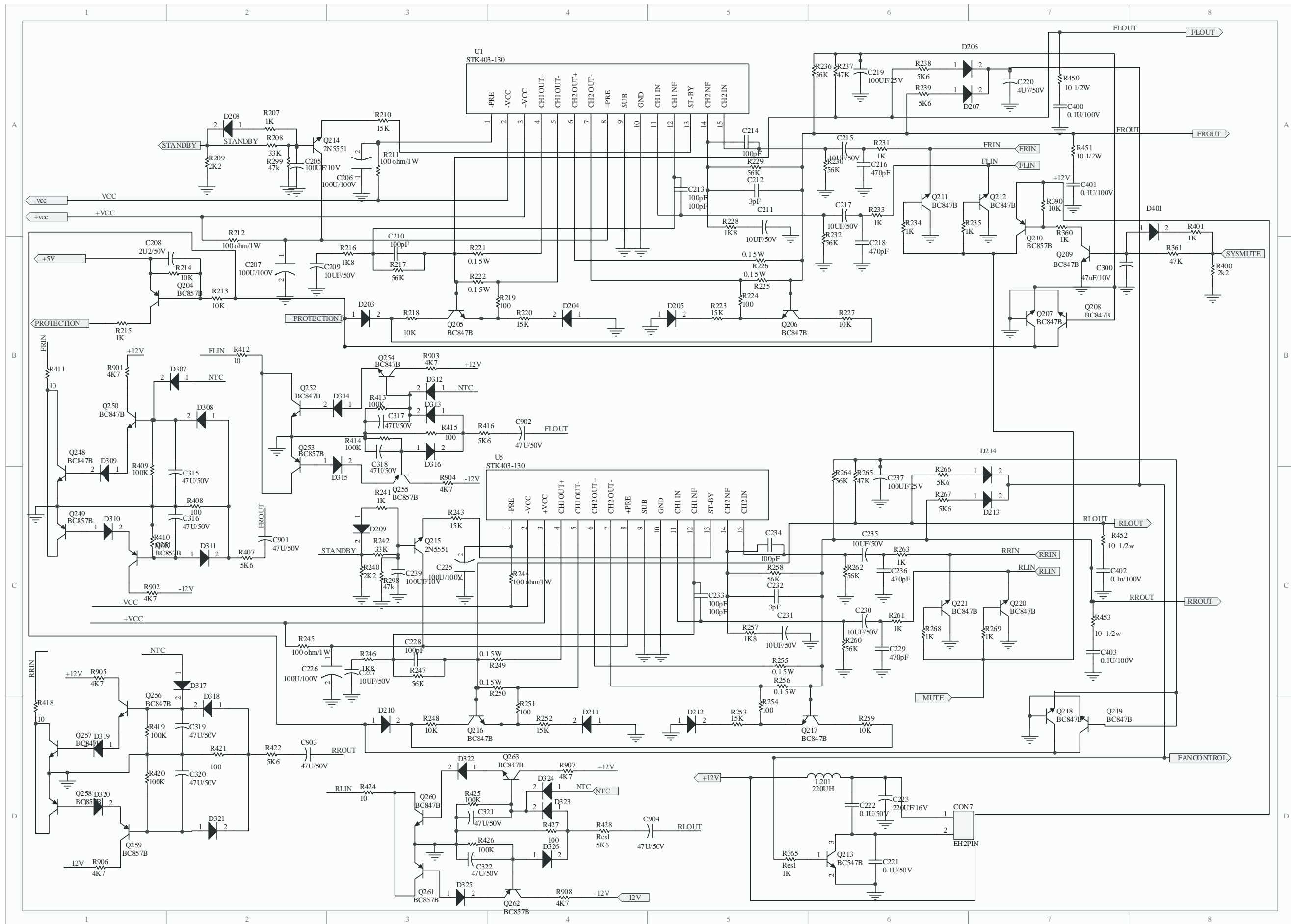

Subwoofer Amplifier - Top view layout

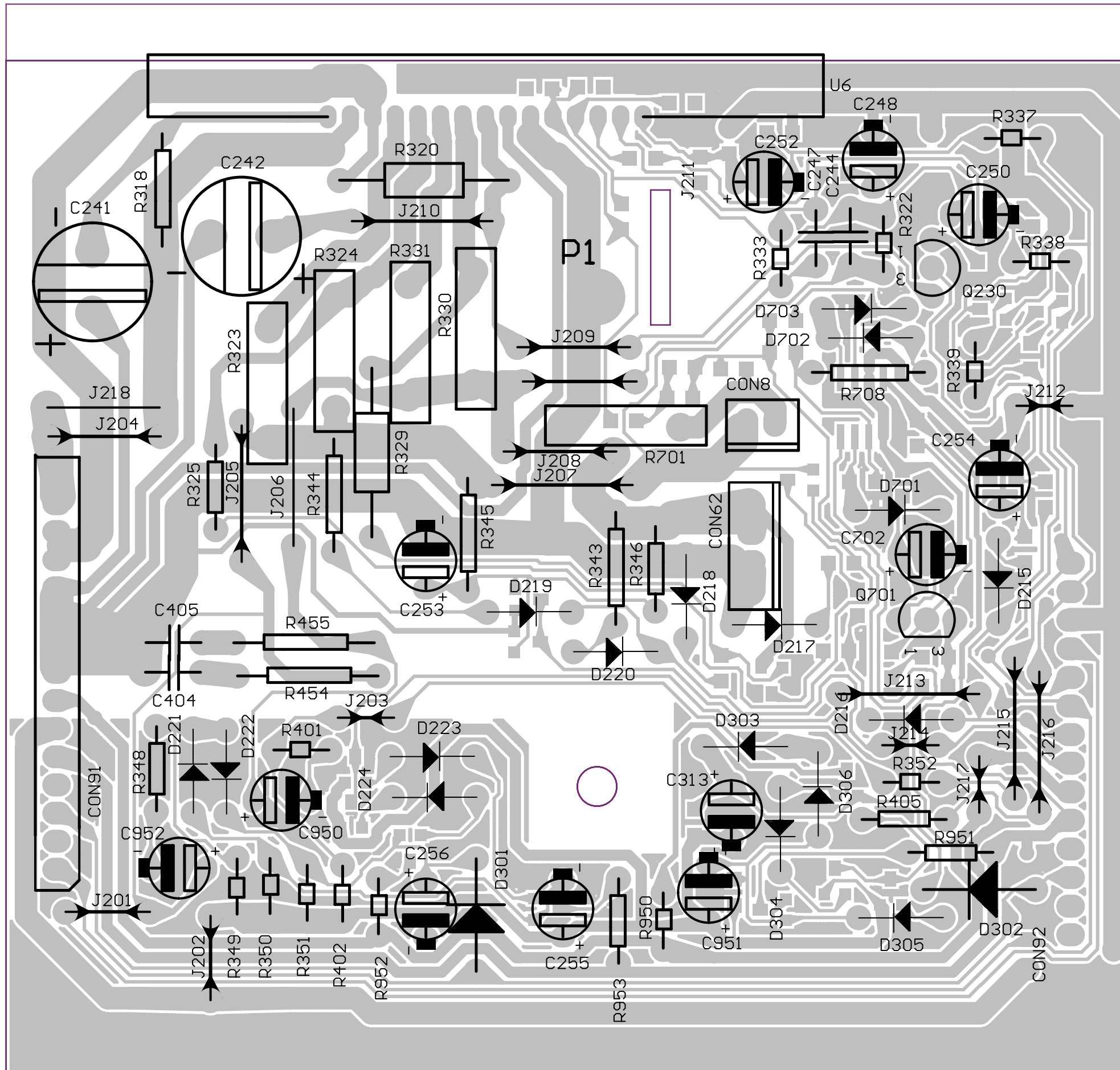

Subwoofer Amplifer - Bottom view layout

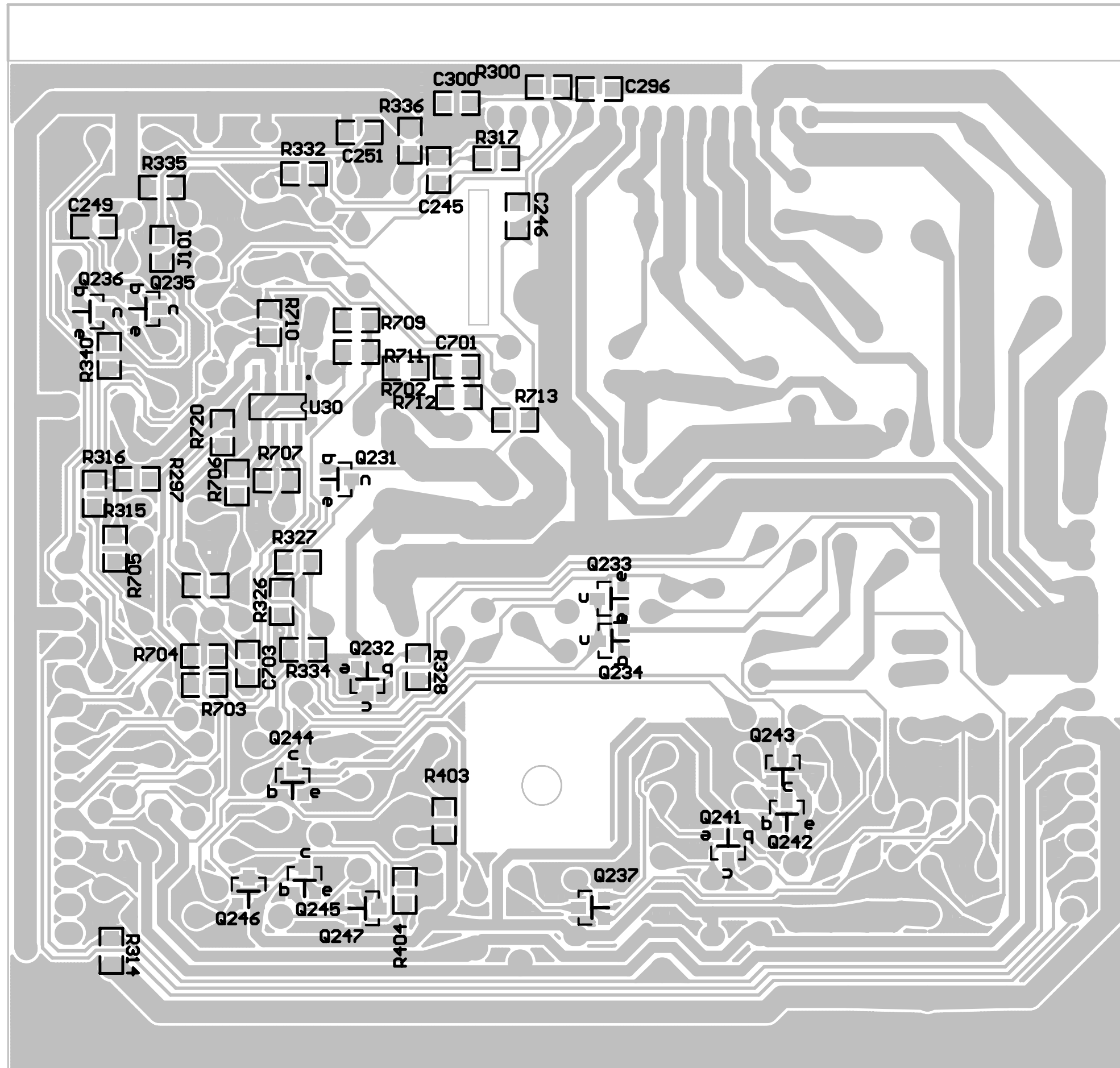

Subwoofer amplifier schematic

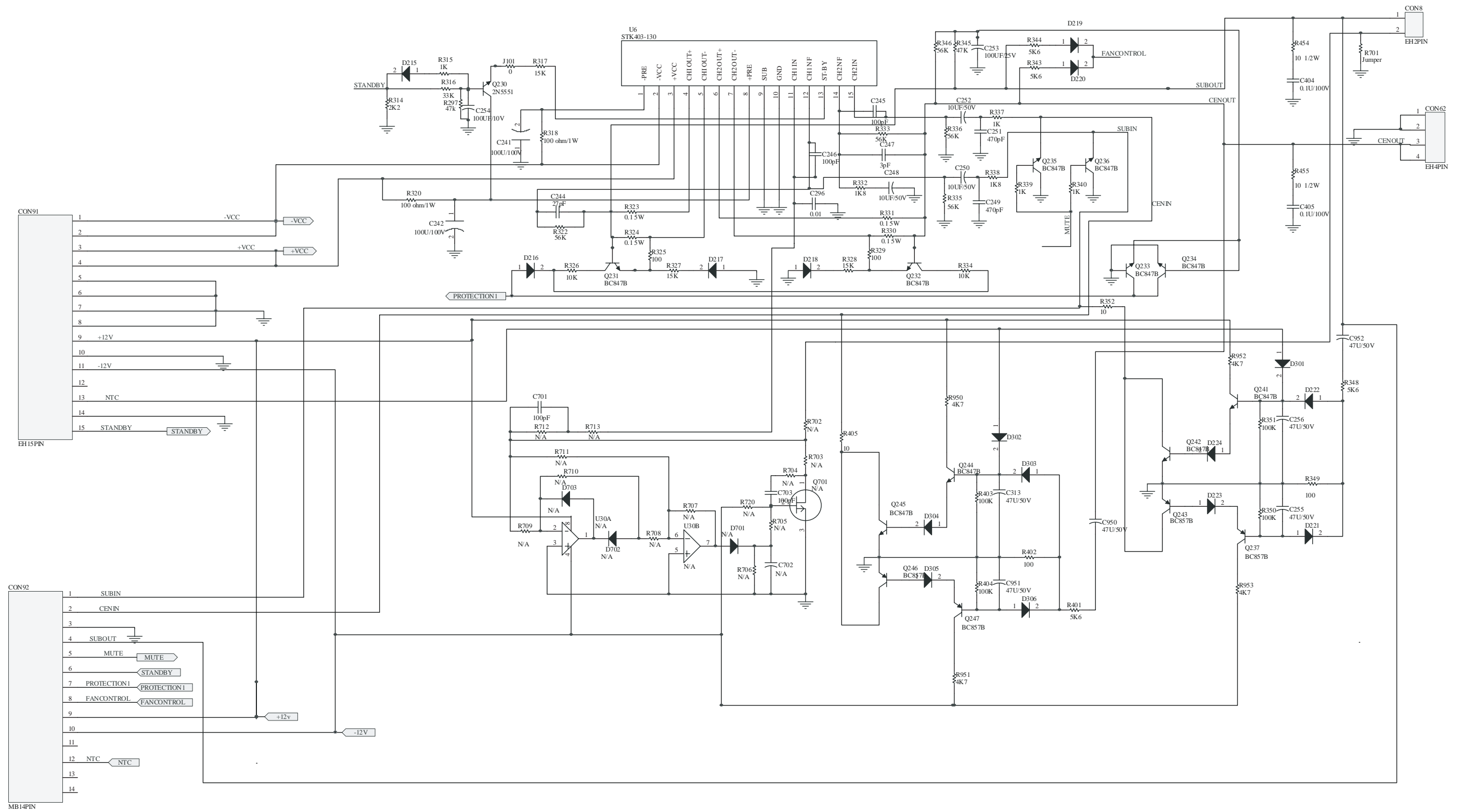

Transformer - Top silk layout

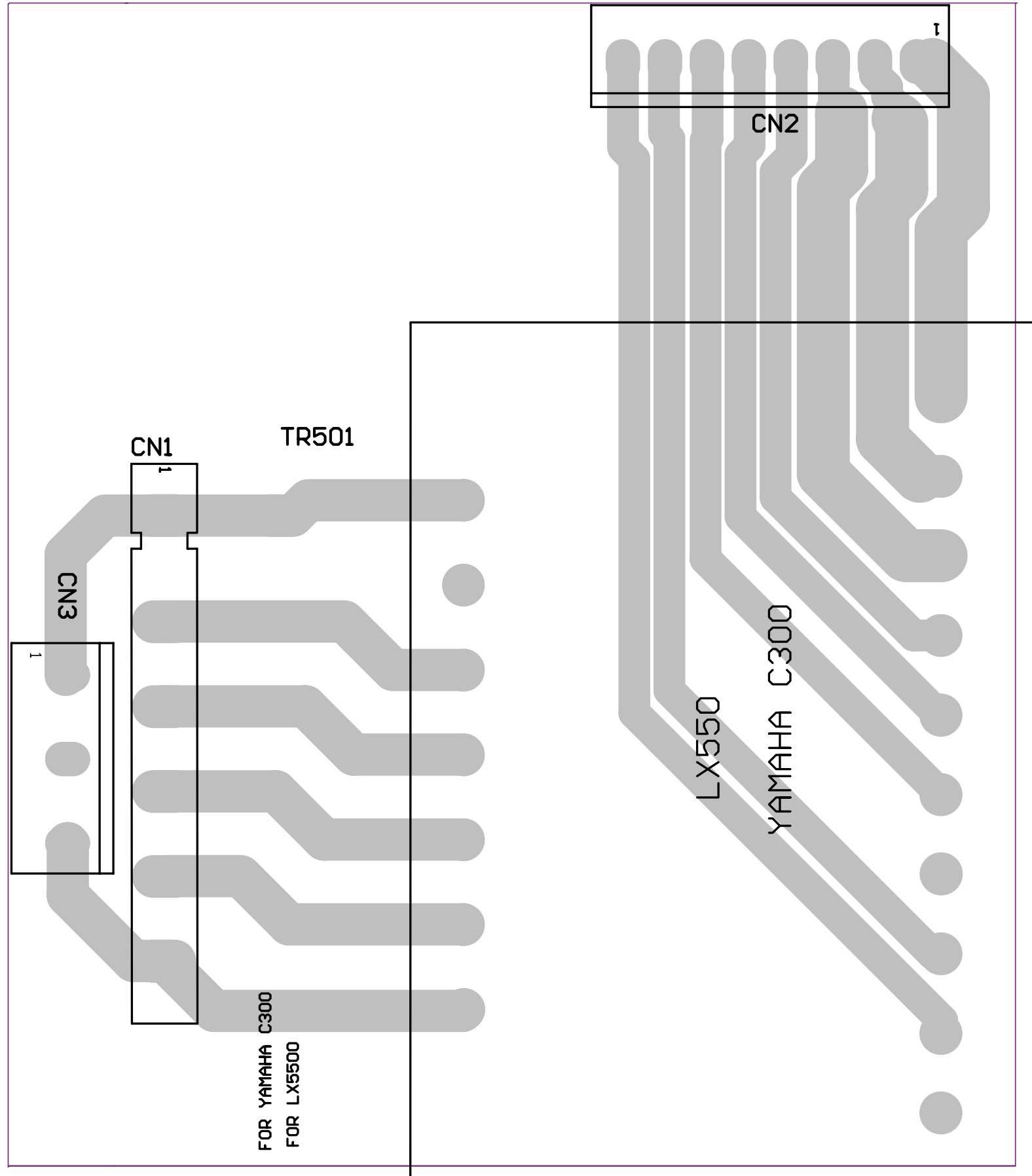

Exploded View - Box Spk Assy SW5500C

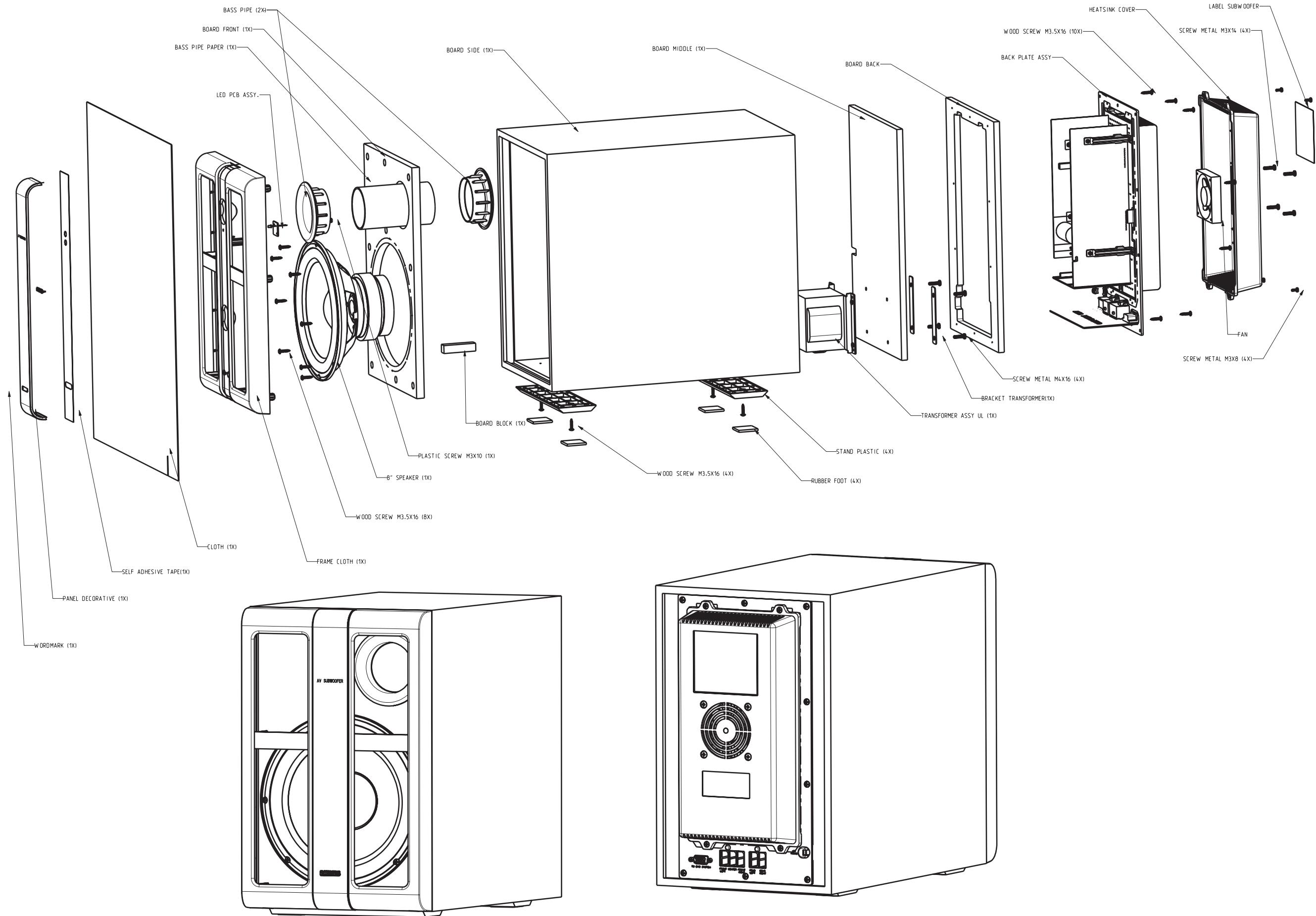

Exploded View - Module

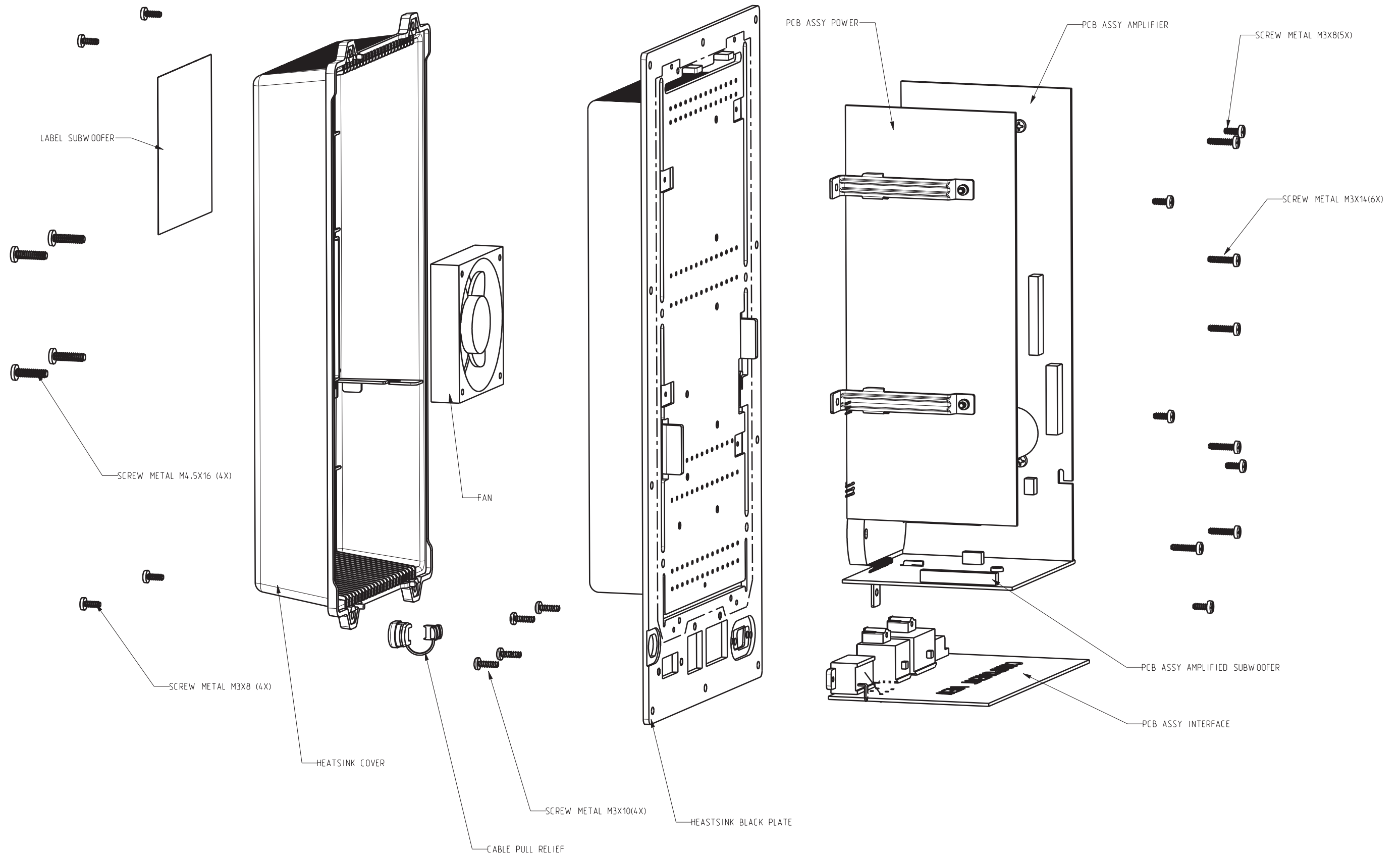

Wiring Diagram SW5500C

WIRING DIAGRAM Model:SW5500C Powerbox serial

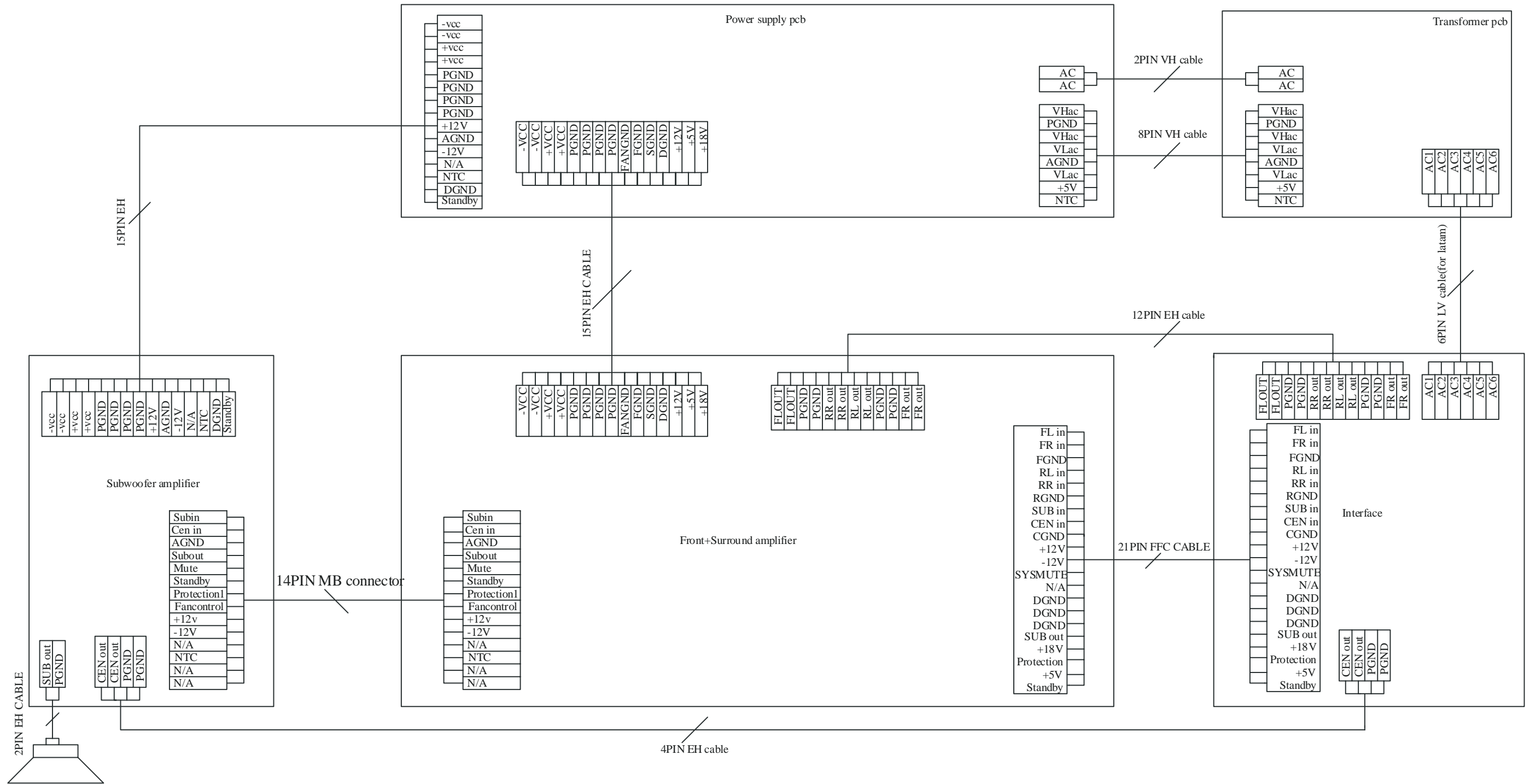

9. Module SD6.3 CH HT SD6.3 CH HT Board - Top View Layout

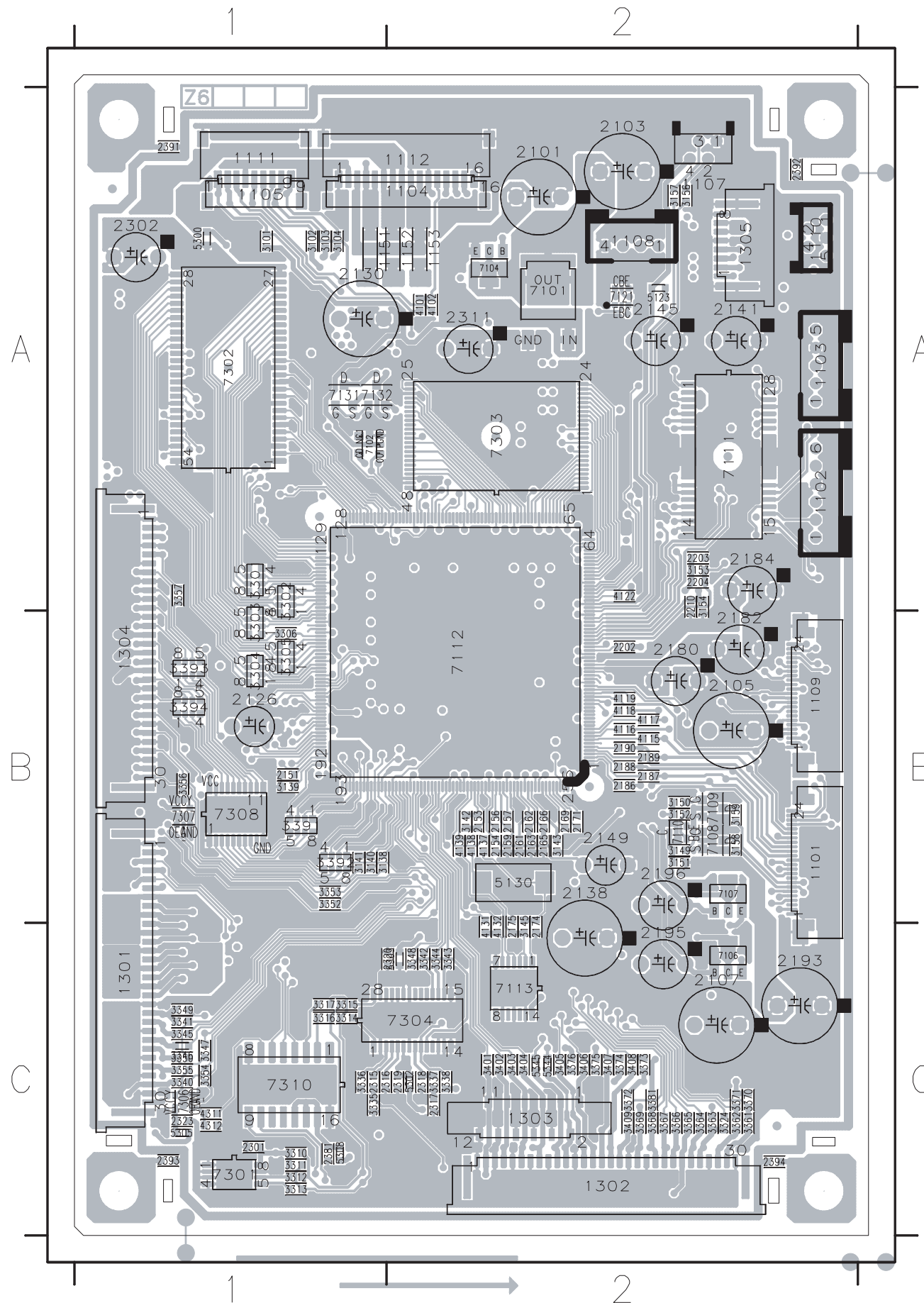

1101	B2	2317	C2	3355	C1	7110	B2
1102	A2	2318	C2	3356	B1	7111	A2
1103	A2	2319	C2	3357	A1	7112	B2
1104	A2	2320	C2	3361	C2	7113	C2
1105	A1	2323	C1	3362	C2	7121	A2
1107	A2	2381	C1	3363	C2	7131	A1
1108	A2	2391	A1	3364	C2	7132	A1
1109	B2	2392	A2	3365	C2	7301	C1
1110	A2	2393	C1	3366	C2	7302	A1
1111	A1	2394	C2	3367	C2	7303	A2
1112	A2	3101	A1	3368	C2	7304	C2
1151	A1	3102	A1	3369	C2	7306	C1
1152	A2	3103	A1	3370	C2	7307	B1
1153	A2	3104	A1	3371	C2	7308	B1
1301	C1	3138	B1	3372	C2	7310	C1
1302	C2	3139	B1	3373	C2		
1303	C2	3140	B1	3374	C2		
1304	B1	3141	B1	3375	C2		
1305	A2	3142	B2	3376	C2		
2101	A2	3143	B2	3381	C2		
2103	A2	3145	C2	3391	B1		
2105	B2	3149	B2	3392	B1		
2107	C2	3150	B2	3393	B1		
2126	B1	3151	B2	3394	B1		
2130	A1	3152	B2	3401	C2		
2138	B2	3153	A2	3402	C2		
2141	A2	3154	A2	3403	C2		
2145	A2	3156	A2	3404	C2		
2149	B2	3157	A2	3405	C2		
2151	B1	3158	B2	3406	C2		
2153	B2	3159	B2	3407	C2		
2154	B2	3301	A1	3408	C2		
2156	B2	3302	A1	3409	C2		
2157	B2	3303	B1	4101	A2		
2159	B2	3304	B1	4102	A2		
2161	B2	3305	B1	4115	B2		
2162	B2	3306	B1	4116	B2		
2163	B2	3310	C1	4117	B2		
2165	B2	3311	C1	4118	B2		
2166	B2	3312	C1	4119	B2		
2169	B2	3313	C1	4122	A2		
2171	B2	3314	C1	4131	C2		
2174	C2	3315	C1	4132	C2		
2175	C2	3316	C1	4137	B2		
2180	B2	3317	C1	4138	B2		
2182	B2	3324	C2	4139	B2		
2184	A2	3335	C1	4311	C1		
2186	B2	3336	C1	4312	C1		
2187	B2	3337	C2	5123	A2		
2188	B2	3338	C2	5130	B2		
2189	B2	3340	C1	5300	A1		
2190	B2	3341	C1	5302	C2		
2193	C2	3342	C2	5303	C2		
2195	C2	3343	C2	5305	C1		
2196	B2	3344	C2	5308	C1		
2202	B2	3345	C1	5344	C2		
2203	A2	3346	C1	5345	C2		
2204	A2	3347	C1	7101	A2		
2210	A2	3348	C2	7102	A1		
2301	C1	3349	C1	7104	A2		
2302	A1	3350	C1	7106	C2		
2311	A2	3352	B1	7107	B2		
2315	C1	3353	B1	7108	B2		
2316	C1	3354	C1	7109	B2		

SD6.3 CH HT Board - Bottom View Layout

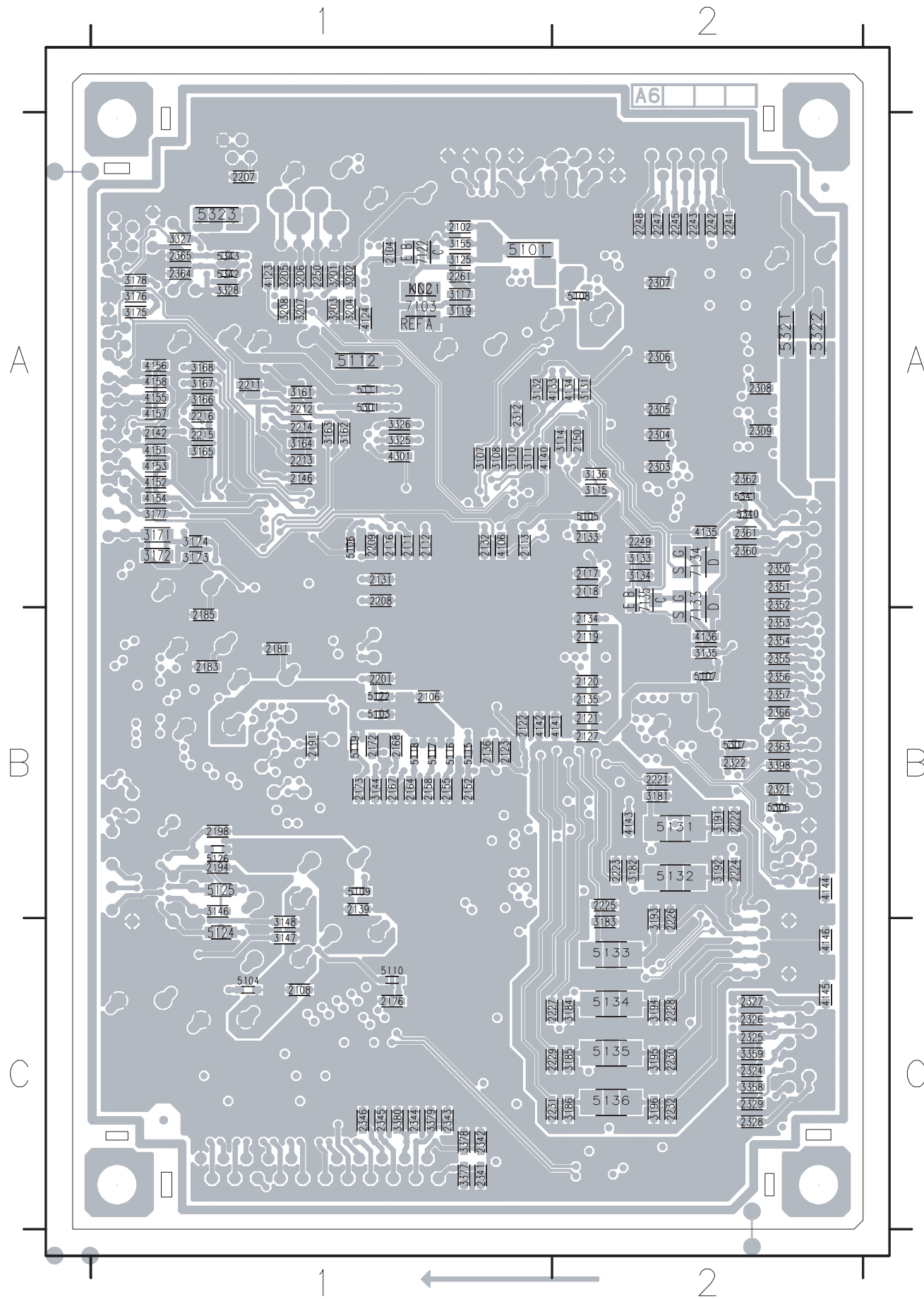

2102	A1	2242	A2	3155	A1	4153	A1
2104	A1	2243	A2	3161	A1	4154	A1
2106	B1	2245	A2	3162	A1	4155	A1
2108	C1	2247	A2	3163	A1	4156	A1
2111	A1	2248	A2	3164	A1	4157	A1
2112	A1	2249	A2	3165	A1	4158	A1
2113	A1	2250	A1	3166	A1	4301	A1
2116	A1	2261	A1	3167	A1	5101	A1
2117	A2	2303	A2	3168	A1	5103	B1
2118	A2	2304	A2	3171	A1	5104	C1
2119	B2	2305	A2	3172	A1	5105	A2
2120	B2	2306	A2	3173	A1	5106	A1
2121	B2	2307	A2	3174	A1	5107	B2
2122	B1	2308	A2	3175	A1	5108	A2
2123	B1	2309	A2	3176	A1	5109	B1
2127	B2	2312	A1	3177	A1	5110	C1
2131	A1	2321	B2	3178	A1	5111	A1
2132	A1	2322	B2	3181	B2	5112	A1
2133	A2	2324	C2	3182	B2	5115	B1
2134	B2	2325	C2	3183	C2	5116	B1
2135	B2	2326	C2	3184	C2	5117	B1
2136	B1	2327	C2	3185	C2	5118	B1
2139	B1	2328	C2	3186	C2	5119	B1
2142	A1	2329	C2	3191	B2	5122	B1
2146	A1	2341	C1	3192	B2	5124	C1
2150	A2	2342	C1	3193	C2	5125	B1
2152	B1	2343	C1	3194	C2	5126	B1
2155	B1	2344	C1	3195	C2	5131	B2
2158	B1	2345	C1	3196	C2	5132	B2
2164	B1	2346	C1	3201	A1	5133	C2
2167	B1	2350	A2	3202	A1	5134	C2
2168	B1	2351	A2	3203	A1	5135	C2
2172	B1	2352	A2	3204	A1	5136	C2
2173	B1	2353	B2	3205	A1	5301	A1
2176	C1	2354	B2	3206	A1	5306	B2
2181	B1	2355	B2	3207	A1	5307	B2
2183	B1	2356	B2	3208	A1	5321	A2
2185	B1	2357	B2	3325	A1	5322	A2
2191	B1	2360	A2	3326	A1	5323	A1
2194	B1	2361	A2	3327	A1	5340	A2
2198	B1	2362	A2	3328	A1	5341	A2
2201	B1	2363	B2	3358	C2	5342	A1
2207	A1	2364	A1	3359	C2	5343	A1
2208	A1	2365	A1	3377	C1	7103	A1
2209	A1	2366	B2	3378	C1	7122	A1
2211	A1	3107	A1	3379	C1	7133	A2
2212	A1	3108	A1	3380	C1	7134	A2
2213	A1	3110	A1	3398	B2	7135	A2
2214	A1	3111	A1	4106	A1		
2215	A1	3114	A2	4123	A1		
2216	A1	3115	A2	4124	A1		
2221	B2	3117	A1	4133	A2		
2222	B2	3119	A1	4134	A2		
2223	B2	3125	A1	4135	A2		
2224	B2	3131	A2	4136	B2		
2225	B2	3132	A1	4140	A1		
2226	C2	3133	A2	4141	B2		
2227	C1	3134	A2	4142	B1		
2228	C2	3135	B2	4143	B2		
2229	C1	3136	A2	4144	B2		
2230	C2	3144	B1	4145	C2		
2231	C1	3146	B1	4146	C2		
2232	C2	3147	C1	4151	A1		
2241	A2	3148	C1	4152	A1		

SD6.3 CH HT Board - Circuit Diagram (Part1)

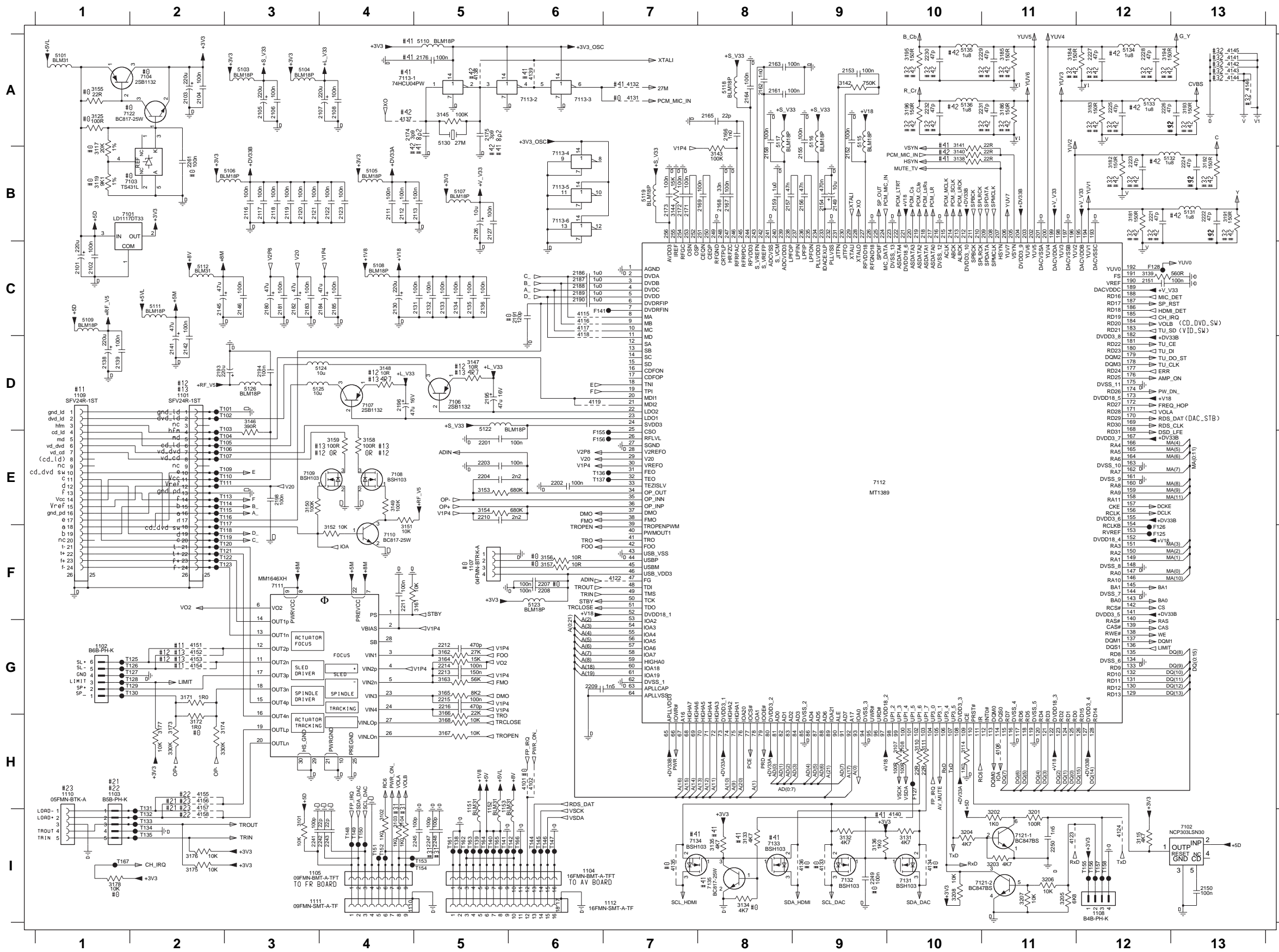

1101 D2	2230 A10	4145 A13	T149 I4
1102 G1	2231 A11	4146 A13	T150 I4
1103 H1	2232 A10	4151 G2	T151 I4
1104 I6	2241 I3	4152 G2	T152 I4
1105 I3	2242 I3	4153 G2	T153 I5
1106 F5	2243 I4	4154 G2	T154 I5
1108 H2	2245 I4	4155 H2	T155 I2
1109 D1	2247 I5	4156 H2	T156 I1
1110 H1	2248 I5	4157 I2	T157 I2
1111 I3	2249 I9	4158 I2	T158 I2
1112 I7	2250 I11	5101 A1	T161 I5
1151 H5	2261 B2	5103 A3	T162 I5
1152 H5	3101 I3	5104 A3	T163 I5
1153 H5	3102 I4	5105 B4	T164 I5
2101 C1	3103 I4	5106 B3	T165 I5
2102 C1	3104 I4	5107 B5	T166 I6
2103 A2	3107 H10	5108 C4	T167 I1
2104 A2	3108 H10	5109 C1	
2105 A3	3110 H10	5110 A5	
2106 A3	3111 H10	5111 C2	
2107 A4	3114 H10	5112 C2	
2108 A4	3115 H12	5115 A9	
2111 B4	3117 B1	5116 A9	
2112 B4	3119 B1	5117 A8	
2113 B5	3125 A1	5118 A8	
2116 B3	3131 I10	5119 B7	
2117 B3	3132 I9	5122 E5	
2118 B3	3133 I8	5122 F6	
2119 B3	3134 I8	5124 D4	
2120 B3	3135 I8	5125 D3	
2121 B3	3136 I9	5126 D3	
2122 B4	3138 B10	5130 A5	
2123 B4	3139 C12	5131 B13	
2126 B5	3140 B10	5132 B12	
2127 B5	3141 B10	5133 A12	
2130 C4	3142 A9	5134 A12	
RD17	3143 B8	5135 A10	
RD18	3144 B7	5136 B7	
RD19	3145 A5	7101 B1	
RD20	3146 D3	7102 I13	
RD21	3147 D5	7103 B1	
RD22	3148 D4	7104 A2	
RD23	3149 E4	7106 D5	
RD24	3149 E3	7107 D4	
RD25	3151 F4	7108 E4	
RD26	3151 F5	7109 E3	
RD27	3152 E5	7110 F4	
RD28	3152 E5	7111 F3	
RD29	3154 A1	7112 E9	
RD30	3154 A1	7113-1 A4	
RD31	3155 A1	7113-2 A6	
RD32	3156 F6	7113-3 A6	
RD33	3156 F6	7113-4 B6	
RD34	3157 F6	7113-5 B6	
RD35	3158 E4	7113-6 B6	
RD36	3158 E4	7113-7 B6	
RD37	3159 E4	7113-8 B6	
RD38	3159 E4	7113-9 B6	
RD39	3160 G5	7113-10 B6	
RD40	3160 G5	7113-11 B6	
RD41	3161 F5	7113-12 B6	
RD42	3162 G5	7113-13 B6	
RD43	3162 G5	7113-14 B6	
RD44	3163 G5	7113-15 B6	
RD45	3163 G5	7113-16 B6	
RD46	3164 G5	7113-17 B6	
RD47	3164 G5	7113-18 B6	
RD48	3165 G5	7113-19 B6	
RD49	3165 G5	7113-20 B6	
RD50	3166 H5	7113-21 B6	
RD51	3166 H5	7113-22 B6	
RD52	3167 H5	7113-23 B6	
RD53	3167 H5	7113-24 B6	
RD54	3168 A8	7113-25 B6	
RD55	3168 A8	7113-26 B6	
RD56	3168 A8	7113-27 B6	
RD57	3168 A8	7113-28 B6	
RD58	3168 A8	7113-29 B6	
RD59	3168 A8	7113-30 B6	
RD60	3168 A8	7113-31 B6	
RD61	3168 A8	7113-32 B6	
RD62	3168 A8	7113-33 B6	
RD63	3168 A8	7113-34 B6	
RD64	3168 A8	7113-35 B6	
RD65	3168 A8	7113-36 B6	
RD66	3168 A8	7113-37 B6	
RD67	3168 A8	7113-38 B6	
RD68	3168 A8	7113-39 B6	
RD69	3168 A8	7113-40 B6	
RD70	3168 A8	7113-41 B6	
RD71	3168 A8	7113-42 B6	
RD72	3168 A8	7113-43 B6	
RD73	3168 A8	7113-44 B6	
RD74	3168 A8	7113-45 B6	
RD75	3168 A8	7113-46 B6	
RD76	3168 A8	7113-47 B6	
RD77	3168 A8	7113-48 B6	
RD78	3168 A8	7113-49 B6	
RD79	3168 A8	7113-50 B6	
RD80	3168 A8	7113-51 B6	
RD81	3168 A8	7113-52 B6	
RD82	3168 A8	7113-53 B6	
RD83	3168 A8	7113-54 B6	
RD84	3168 A8	7113-55 B6	
RD85	3168 A8	7113-56 B6	
RD86	3168 A8	7113-57 B6	
RD87	3168 A8	7113-58 B6	
RD88	3168 A8	7113-59 B6	
RD89	3168 A8	7113-60 B6	
RD90	3168 A8	7113-61 B6	
RD91	3168 A8	7113-62 B6	
RD92	3168 A8	7113-63 B6	
RD93	3168 A8	7113-64 B6	
RD94	3168 A8	7113-65 B6	
RD95	3168 A8	7113-66 B6	
RD96	3168 A8	7113-67 B6	
RD97	3168 A8	7113-68 B6	
RD98	3168 A8	7113-69 B6	
RD99	3168 A8	7113-70 B6	
RD100	3168 A8	7113-71 B6	
RD101	3168 A8	7113-72 B6	
RD102	3168 A8	7113-73 B6	
RD103	3168 A8	7113-74 B6	
RD104	3168 A8	7113-75 B6	
RD105	3168 A8	7113-76 B6	
RD106	3168 A8	7113-77 B6	
RD107	3168 A8	7113-78 B6	
RD108	3168 A8	7113-79 B6	
RD109	3168 A8	7113-80 B6	
RD110	3168 A8	7113-81 B6	
RD111	3168 A8	7113-82 B6	
RD112	3168 A8	7113-83 B6	
RD113	3168 A8	7113-84 B6	
RD114	3168 A8	7113-85 B6	
RD115	3168 A8	7113-86 B6	
RD116	3168 A8	7113-87 B6	
RD117	3168 A8	7113-88 B6	
RD118	3168 A8	7113-89 B6	
RD119	3168 A8	7113-90 B6	
RD120	3168 A8	7113-91 B6	
RD121	3168 A8	7113-92 B6	
RD122	3168 A8	7113-93 B6	
RD123	3168 A8	7113-94 B6	
RD124	3168 A8	7113-95 B6	
RD125	3168 A8	7113-96 B6	
RD126	3168 A8	7113-97 B6	
RD127	3168 A8	7113-98 B6	
RD128	3168 A8	7113-99 B6	
RD129	3168 A8	7113-100 B6	

#0 PROVISION #11 DV33 #21 WXD-8136 #31 RECEIVERS #41 DIGITAL VIDEO
 #12 DV34 #22 WXD-8229 #32 PLAYERS #42 ANALOG VIDEO
 #13 KHM310 #23 DLM-1D
 #24 5DCD

SD6.3 CH HT Board - Circuit Diagram (Part2)

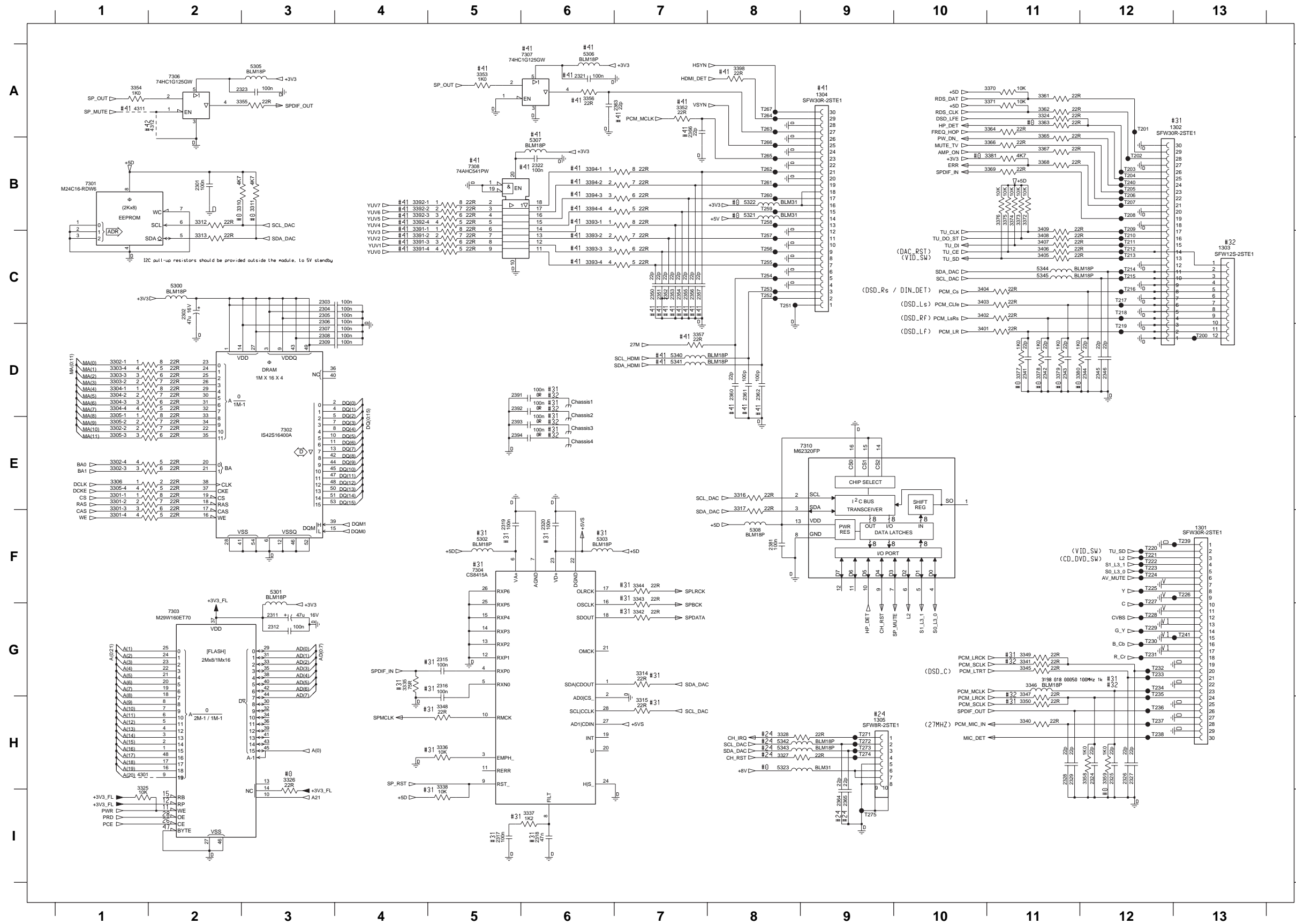

1301 F13	3359 H12	T236 H12
1302 A13	3361 A11	T237 H12
1303 C13	3362 A11	T238 H12
1304 A9	3363 A11	T239 F13
1305 H9	3364 A11	T240 B12
2301 B2	3365 B11	T241 G13
2302 C2	3366 B11	T251 C8
2303 C3	3367 B11	T252 C8
2304 C3	3368 B11	T253 C8
2305 C3	3369 B11	T254 C8
2306 D3	3370 A11	T255 C8
2307 D3	3371 A11	T256 C8
2308 D3	3372 B11	T257 C8
2309 D3	3373 B11	T258 B8
2310 G3	3374 B11	T259 B8
2311 G3	3375 B11	T260 B8
2312 G5	3376 B11	T261 B8
2313 G5	3377 D11	T262 B8
2314 I5	3378 D11	T263 A8
2315 I6	3379 D11	T264 A8
2316 F5	3380 D11	T265 B8
2317 F5	3381 B11	T266 B8
2318 A6	3391-1 C4	T267 A8
2319 A6	3391-2 C4	T271 H9
2320 B6	3391-3 C4	T272 H9
2321 A3	3391-4 C4	T273 H9
2322 H12	3392-1 B4	T274 H9
2323 H12	3392-2 B4	T275 I9
2324 H12	3392-3 B4	
2325 H12	3392-4 B4	
2326 H12	3393-1 B6	
2327 H12	3393-2 C6	
2328 H11	3393-3 C6	
2329 H11	3393-4 C6	
2330 H11	3394-1 B6	
2331 D11	3394-2 B6	
2332 D11	3394-3 B6	
2333 D12	3394-4 B6	
2334 D12	3394-5 B6	
2335 D12	3394-6 B6	
2336 D12	3394-7 B6	
2337 C7	3398 A8	
2338 C7	3401 D10	
2339 C7	3402 C10	
2340 C7	3403 C10	
2341 C7	3404 C10	
2342 C7	3405 C11	
2343 C7	3406 C11	
2344 D8	3407 C11	
2345 D8	3408 C11	
2346 D8	3409 C11	
2347 D8	3410 H1	
2348 A7	4311 A1	
2349 A7	4312 A2	
2350 A7	5300 C2	
2351 F8	5301 F3	
2352 D5	5302 F5	
2353 D5	5303 F6	
2354 E5	5305 A3	
2355 E5	5306 A6	
2356 E1	5307 B6	
2357 E1	5308 F8	
2358 F1	5321 B8	
2359 F1	5322 B8	
2360 D1	5323 H8	
2361 D1	5340 D7	
2362 E1	5341 D7	
2363 E1	5342 H8	
2364 D1	5343 H8	
2365 D1	5344 C11	
2366 D1	5345 C11	
2367 D1	7301 B1	
2368 D1	7302 E3	
2369 D1	7303 G2	
2370 D1	7304 F5	
2371 E1	7306 A2	
2372 E1	7307 A6	
2373 E1	7308 B5	
2374 E1	7310 E8	
2375 E1	7310 E8	
2376 E1	7310 E8	
2377 E1	7310 E8	
2378 E1	7310 E8	
2379 E1	7310 E8	
2380 E1	7310 E8	
2381 E1	7310 E8	
2382 E1	7310 E8	
2383 E1	7310 E8	
2384 E1	7310 E8	
2385 E1	7310 E8	
2386 E1	7310 E8	
2387 E1	7310 E8	
2388 E1	7310 E8	
2389 E1	7310 E8	
2390 E1	7310 E8	
2391 E1	7310 E8	
2392 E1	7310 E8	
2393 E1	7310 E8	
2394 E1	7310 E8	
2395 E1	7310 E8	
2396 E1	7310 E8	
2397 E1	7310 E8	
2398 E1	7310 E8	
2399 E1	7310 E8	
2400 E1	7310 E8	

#0 PROVISION	#11 DV33	#21 WXD-8136	#31 RECEIVERS	#41 DIGITAL VIDEO
	#12 DV34	#22 WXD-8229	#32 PLAYERS	#42 ANALOG VIDEO
	#13 KHM310	#23 DLM-1D		
		#24 5CDC		

10. Set Mechanical Exploded View

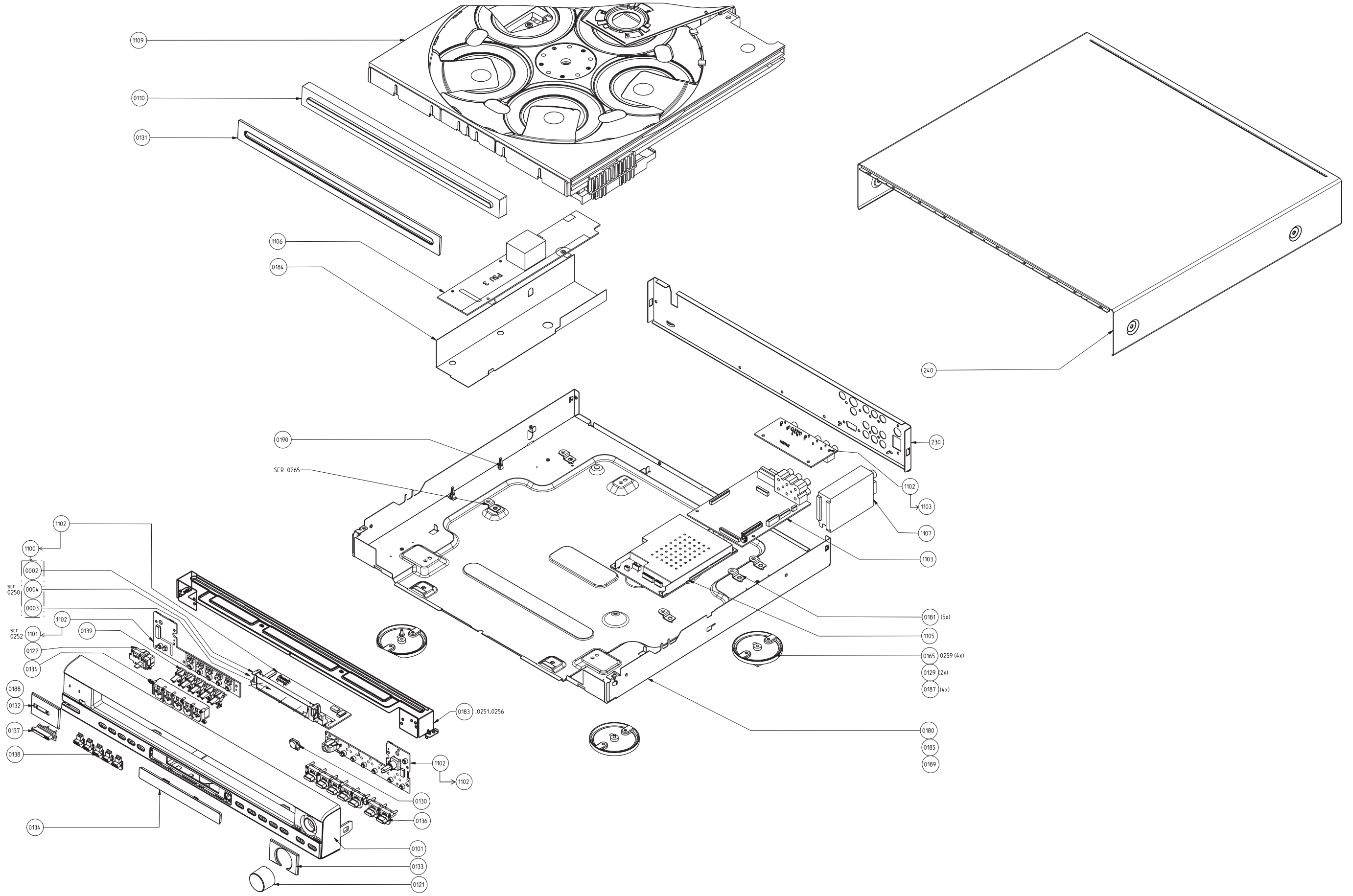

Notes:

MECHANICAL & ACCESSORIES PART LIST**MISCELLANEOUS**

0122	3139 254 01771	BUTTON-POWER-HTS5500
0130	3139 254 00841	LIGHTGUIDE IR SENSOR LX8300
0131	3139 254 01831	PANEL-FRONT-HTS5500
0132	3139 254 01821	PANEL-LEFT-HTS5500
0133	3139 254 01811	PANEL-RIGHT-HTS5500
0134	3139 254 01801	BUTTON-FIVE-DISC-HTS5500
0135	3139 254 01791	WINDOW-DISPLAY-HTS5500
0136	3139 254 01781	BUTTON-CTRL-CHGE-EJ-HTS5500
0137	3139 254 01761	CAP- FOR- BUTTON-POWER-HTS5500
0138	3139 254 01751	CAP-BTN-FIVE-DISC-HTS5500
0139	3139 254 01741	LIGHT-GUIDE-FIVE-DISC-HTS5500
0165	3139 244 03951	FOOT 7-5 YDV-S640
0180	3139 241 22051	FRAME DVD-C750
0181	3139 241 22011	BRACKET PSU DVD C750
0184	3139 243 20091	PSU PROTECTION SHEET
0187	3139 243 10181	CUSHION-FELT
0343	2422 076 00654	CBLE HD-SUB15P 3M HD-SUB 15P B
0325	3139 119 02831	BOX SPK ASSY CS HTS5500C/37
0326	3139 119 02821	BOX SPK ASSY SW HTS5500S/37
0326	3139 119 02921	BOX SPK ASSY SW HTS5500C/55
0331	2422 076 00546	CBLE FM AERIAL 24AWG BK B
0332	2422 549 45386	ANT AM LOOP LAN-011 B
0333	3139 258 70091	REMOTE CONTROL HTS5500
0336	2422 070 98235	△ MAINSCORD UL 6A 1M8 VH BK B
0338	4822 321 61579	VIDEO-CABLE
0341	3103 308 92610	CABLE AUDIO 2X2RCA MALE 1.5MTR

**BOX SPK ASSY CS HTS5500C/37
SATELLITE SPEAKER BOXES(PPS)****MISCELLANEOUS**

4341 078 60251	CENTER BOX ASSEMBLY
4341 078 60261	FRONT SATELLITE RIGHT ASSEMBLY
4341 078 60271	FRONT SATELLITE LEFT ASSEMBLY
4341 078 60281	REAR SATELLITE RIGHT ASSEMBLY
4341 078 60291	REAR SATELLITE LEFT ASSEMBLY
4341 074 50791	BRACKET
4340 704 20221	SCREW M5X14
4341 078 60301	CLOTH FRAME ASSY - CENTER
4340 704 50281	RUBBER FOOT
4341 070 25301	EASY CONNECTOR IN GREEN -5M CENT
4341 078 60311	CLOTH FRAME ASSY - SATELLITE
4341 070 25311	EASY CONNECTOR IN RED
4341 070 25321	EASY CONNECTOR IN WHITE
4341 070 25331	EASY CONNECTOR IN GRE
4341 070 25341	EASY CONNECTOR IN BLU

ACTIVE SUBWOOFER (PPS)**MISCELLANEOUS**

3141 137 40071	PCB ASSY - AMPLIFER
3141 137 40021	PCB ASSY - INTERFACE
3141 137 40101	PCB ASSY - AMPLIFER SUB
3141 137 40151	PCB ASSY - POWER ASSY
3141 137 60021	AC CORD U/C
3141 137 60321	WIRE ASSY
4341 078 90021	FRAME - CLOTH ASSY
4340 704 50291	RUBBER FOOT
3141 137 40121	TRANSFORMER ASSY

BOX SPK ASSY SW HTS5500C/55**ACTIVE SUBWOOFER (PPS)****MISCELLANEOUS**

3141 137 40071	PCB ASSY - AMPLIFER
3141 137 40141	PCB ASSY - INTERFACE
3141 137 40101	PCB ASSY - AMPLIFER SUB
3141 137 40151	PCB ASSY - POWER ASSY
3141 137 60291	AC CORD LATAM
3141 137 60331	WIRE ASSY
4341 078 90021	FRAME - CLOTH ASSY
4340 704 50291	RUBBER FOOT
3141 137 40131	TRANSFORMER ASSY

ELECTRICAL PARTS LIST**MISCELLANEOUS**

1102	3139 248 84301	PCBAS FRONT PANEL HTS5500/37
1103	3139 118 58661	PCBAS AV PANEL HTS5500
1106	3139 117 11111	MODULESMPS 04-20
1107	2422 542 00022	TUN A F ENG06703QF USA B
1109	3139 248 71992	MOD SD5.5
1109	3141 079 32991	MOD SD5.5 PACKAGING
1102	3139 118 58641	PCBAS FRONT KEY HTS5500
1200	3139 118 58671	PCBAS AV HTS5500

ELECTRICAL PARTS LIST - PCBAS FRONT IO HTS5500**MISCELLANEOUS**

1200	2422 025 17501	CON BM H 15P F 1.00 FFC SMT R
1202	4822 276 13775	SWITCH
1203	4822 276 13775	SWITCH
1204	4822 276 13775	SWITCH
1205	4822 276 13775	SWITCH
1206	4822 276 13775	SWITCH
1208	4822 276 13775	SWITCH
5200	3198 018 31590	FXDIND SM 0805 15U PM20 COL R

DIODES

6200	4822 130 11416	PDZ6.8B
6201	4822 130 11416	PDZ6.8B
6202	9322 184 08676	LED VS LTL-816YE (LITO) A
6203	9322 184 08676	LED VS LTL-816YE (LITO) A
6204	9322 184 08676	LED VS LTL-816YE (LITO) A
6205	9322 184 08676	LED VS LTL-816YE (LITO) A
6206	9322 184 08676	LED VS LTL-816YE (LITO) A
6207	9322 183 96676	LED VS LTL-816GE (LITO) A
6208	9322 183 96676	LED VS LTL-816GE (LITO) A
6209	9322 183 96676	LED VS LTL-816GE (LITO) A
6210	9322 183 96676	LED VS LTL-816GE (LITO) A
6211	9322 183 96676	LED VS LTL-816GE (LITO) A
6212	9322 179 76676	LED VS LTL-816EELC (LITO) A

TRANSISTORS & INTREGATED CIRCUITS

7200	3198 010 42320	BC857BW
7201	3198 010 42320	BC857BW
7202	3198 010 42320	BC857BW
7203	3198 010 42320	BC857BW
7204	3198 010 42320	BC857BW

ELECTRICAL PARTS LIST - PCBAS FRONT KEY HTS5500 MISCELLANEOUS

1100	2422 025 17033	CON H 8P F 1.00 SM FFC 0.3 R
1101	2422 025 16806	CON BM H 7P F 1.00 FFC SMT R
1102	2422 129 16975	ROT ENCODER 12P EVEMC2F2512B B
1104	4822 276 13775	SWITCH
1105	4822 276 13775	SWITCH
1106	4822 276 13775	SWITCH
1107	4822 276 13775	SWITCH
1110	4822 276 13775	SWITCH
1113	4822 276 13775	SWITCH
1114	4822 276 13775	SWITCH

DIODES

6100	4822 130 11416	PDZ6.8B
6101	4822 130 11416	PDZ6.8B
6102	4822 130 11416	PDZ6.8B
6103	4822 130 11416	PDZ6.8B

ELECTRICAL PARTS LIST - PCBAS FRONT DISP HTS5500/37 MISCELLANEOUS

1301	2422 025 17201	CON H 9P F 1.00 SM FFC 0.3 R
1302	2422 025 17033	CON H 8P F 1.00 SM FFC 0.3 R
1303	2422 025 17501	CON BM H 15P F 1.00 FFC SMT R
5300	3198 018 52280	FXDIND SM 0603 2U2 PM10 COL R

DIODES

6301	4822 130 10837	UDZS8.2B
6302	3198 020 55680	DIO REG SM BZX384-C5V6 COL R
6304	4822 130 11397	BAS316
6305	4822 130 11397	BAS316
6306	4822 130 11397	BAS316
6307	4822 130 11397	BAS316

TRANSISTORS & INTREGATED CIRCUITS

7300	9322 205 06671	IC SM TMP87PM74ZF (TOSJ) Y
7301	2722 171 00201	VFD 12-ST-50GNK 100*16 (FTBD)B
7302	9322 202 67667	IR RECEIVER TSOP34836UH1(VISH)
7303	4822 130 40981	BC337-25
7304	4822 130 41246	BC327-25
7305	3198 010 42310	BC847BW
7306	3198 010 42310	BC847BW
7308	3198 010 42310	BC847BW
7309	3198 010 42310	BC847BW
7310	3198 010 42320	BC857BW
7311	3198 010 42310	BC847BW
7312	3198 010 42320	BC857BW

ELECTRICAL PARTS LIST- PCBAS VIDEO CONN HTS5500 MISCELLANEOUS

1400	2422 025 17154	CON BM V 20P F 1.00 FFC 0.3 B
1401	2422 026 05419	SOC CINCH H 1P F 1L1 BK B
1402	2422 033 00468	SOC COMBI H 2P F CINCH/MDIN Y
1403	2422 026 05589	SOC CINCH H 3P F 1L3 RDBUGN Y

DIODES

6400	4822 130 11522	UDZ15B
6401	4822 130 11522	UDZ15B
6402	4822 130 11522	UDZ15B
6406	4822 130 11522	UDZ15B
6407	4822 130 11522	UDZ15B
6408	4822 130 11522	UDZ15B
6409	4822 130 11522	UDZ15B

ELECTRICAL PARTS LIST - PCBAS AV PANEL HTS5500 MISCELLANEOUS

1100	2422 025 17154	CON BM V 20P F 1.00 FFC 0.3 B
1101	2422 025 18364	CON V 16P F 1.00 FFC 0.3 Y
1102	2422 025 17509	CON BM V 30P F 1.00 FFC 0.3 B
1201	2422 025 17509	CON BM V 30P F 1.00 FFC 0.3 B
1300	2422 025 18766	SOC SUBD H 15P F BU 1216 Y
1402	2422 086 11092	△ FUSE SM F 500MA 50V UL R
1403	2422 086 11103	FUSE SM F 2A 125V UL R
1404	2422 025 09405	CON BM V 2P M 2.00 PH B
1405	2422 086 11103	FUSE SM F 2A 125V UL R
1503	4822 267 11039	11P. FEM.
1504	4822 267 31449	SOC CINCH H 6P F
1601	2422 025 16806	CON BM H 7P F 1.00 FFC SMT R

RESISTORS

3272	2422 549 43062	IND FXD SM EMI 100MHZ 600R R
3493	4822 117 11151	△ FIXED RESISTOR 1R 5%
3494	4822 117 11151	△ FIXED RESISTOR 1R 5%
5206	2422 549 43062	IND FXD SM EMI 100MHZ 600R R
5207	2422 549 43062	IND FXD SM EMI 100MHZ 600R R
5208	2422 549 43062	IND FXD SM EMI 100MHZ 600R R
5209	2422 549 43062	IND FXD SM EMI 100MHZ 600R R
5210	2422 549 43062	IND FXD SM EMI 100MHZ 600R R
5211	2422 549 43062	IND FXD SM EMI 100MHZ 600R R
5401	4822 157 11717	BLM31P500SPT
5402	4822 157 11499	BLM11P600SPT
5403	4822 157 11717	BLM31P500SPT
5404	2422 535 94092	IND FXD SM 0805 33U PM10 R
5405	2422 535 94092	IND FXD SM 0805 33U PM10 R

DIODES

6205	3198 020 55680	DIO REG SM BZX384-C5V6 COL R
6206	4822 130 11397	BAS316
6208	4822 130 11564	UDZ3.9B
6210	4822 130 11397	BAS316
6300	4822 130 11397	BAS316
6301	4822 130 11397	BAS316
6302	4822 130 11397	BAS316
6303	4822 130 11397	BAS316
6304	4822 130 11397	BAS316
6306	4822 130 11397	BAS316
6307	4822 130 11397	BAS316
6308	4822 130 11397	BAS316
6309	4822 130 11397	BAS316
6310	4822 130 11397	BAS316
6311	4822 130 11397	BAS316
6501	4822 130 11551	UDZS10B
6502	4822 130 11397	BAS316
6503	4822 130 11397	BAS316

TRANSISTORS & INTREGATED CIRCUITS

7101	4822 130 42804	BC817-25
7105	9322 177 91685	IC SM TC7WHU04FU (TOSJ) R
7200	9322 203 36668	IC SM CS42418-CQ (CILO) R
7201	9322 119 42685	IC SM MC78FC33H (MOTA) R
7203	4822 130 40959	BC547B
7205	4822 130 40959	BC547B
7300	4822 209 31378	NJM4556MB
7301	4822 209 30095	LM833D
7302	4822 209 30095	LM833D
7310	4822 130 42804	BC817-25
7311	4822 130 42804	BC817-25
7312	4822 130 42804	BC817-25
7313	4822 130 42804	BC817-25
7314	4822 130 60373	BC856B
7315	4822 130 42804	BC817-25
7316	4822 130 42804	BC817-25
7317	4822 130 42804	BC817-25
7318	4822 130 42804	BC817-25
7319	4822 130 60373	BC856B
7320	4822 130 60373	BC856B
7321	4822 130 11397	BAS316
7322	4822 130 42804	BC817-25

TRANSISTORS & INTREGATED CIRCUITS

7323	4822 130 42804	BC817-25
7324	4822 130 42804	BC817-25
7401	5322 130 62804	BCP53
7402	5322 130 60159	BC846B
7403	4822 209 17398	LD1117DT33
7404	9322 146 75685	IC SM TS431L (ST00) R
7405	9322 199 24668	IC SM L7808CD2T (ST00) R
7501	5322 130 44647	BC368
7504	5322 130 60159	BC846B
7505	4822 130 60373	BC856B
7506	5322 130 60159	BC846B
7507	4822 209 30095	LM833D
7508	5322 209 11102	HEF4052BT

ELECTRICAL PARTS LIST - PCBAS SD6.3 CH HT**MISCELLANEOUS**

1101	2422 025 17529	CON BM H 24P F 0.50 FFC 0.3 R
1104	2422 025 16388	CON BM V 16P F 1.00 FFC 0.3 R
1105	2422 025 17768	CON V 9P F 1.00 SM FFC 0.3 R
1151	4822 157 11717	BLM31P500SPT
1152	4822 157 11717	BLM31P500SPT
1153	4822 157 11717	BLM31P500SPT
1301	2422 025 17451	CON BM H 30P F 1.00 FFC 0.3 R
1302	2422 025 17451	CON BM H 30P F 1.00 FFC 0.3 R
1305	2422 025 16968	CON BM H 8P F 1.00 FFC 0.3 R

RESISTORS

3301	2350 035 10229	RST NETW SM ARV24 4X22R PM5 R
3302	2350 035 10229	RST NETW SM ARV24 4X22R PM5 R
3303	2350 035 10229	RST NETW SM ARV24 4X22R PM5 R
3304	2350 035 10229	RST NETW SM ARV24 4X22R PM5 R
3305	2350 035 10229	RST NETW SM ARV24 4X22R PM5 R
3346	4822 157 11499	BLM11P600SPT
3365	2422 549 43062	IND FXD SM EMI 100MHZ 600R R
3367	2422 549 43062	IND FXD SM EMI 100MHZ 600R R

DIODES

5101	4822 157 11717	BLM31P500SPT
5103	4822 157 11499	BLM11P600SPT
5104	4822 157 11499	BLM11P600SPT
5105	4822 157 11499	BLM11P600SPT
5106	4822 157 11499	BLM11P600SPT
5107	4822 157 11499	BLM11P600SPT
5108	4822 157 11499	BLM11P600SPT
5109	4822 157 11499	BLM11P600SPT
5111	4822 157 11499	BLM11P600SPT
5112	4822 157 11717	BLM31P500SPT
5115	4822 157 11499	BLM11P600SPT
5116	4822 157 11499	BLM11P600SPT
5117	4822 157 11499	BLM11P600SPT
5118	4822 157 11499	BLM11P600SPT
5119	4822 157 11499	BLM11P600SPT
5122	4822 157 11499	BLM11P600SPT
5123	4822 157 11499	BLM11P600SPT
5124	3198 018 31090	FXDIND SM 0805 10U PM10 COL R
5125	3198 018 31090	FXDIND SM 0805 10U PM10 COL R
5126	4822 157 11499	BLM11P600SPT
5130	2422 543 01393	RES XTL SM 27MHZ 10P CX8045 R

DIODES

5131	3198 018 41880	FXDIND SM 1210 1U8 PM5 COL R
5132	3198 018 41880	FXDIND SM 1210 1U8 PM5 COL R
5133	3198 018 41880	FXDIND SM 1210 1U8 PM5 COL R
5134	3198 018 41880	FXDIND SM 1210 1U8 PM5 COL R
5135	3198 018 41880	FXDIND SM 1210 1U8 PM5 COL R
5136	3198 018 41880	FXDIND SM 1210 1U8 PM5 COL R
5300	4822 157 11499	BLM11P600SPT
5301	4822 157 11499	BLM11P600SPT
5302	4822 157 11499	BLM11P600SPT
5303	4822 157 11499	BLM11P600SPT
5305	4822 157 11499	BLM11P600SPT
5308	4822 157 11499	BLM11P600SPT
5342	4822 157 11499	BLM11P600SPT
5343	4822 157 11499	BLM11P600SPT
5344	4822 157 11499	BLM11P600SPT
5345	4822 157 11499	BLM11P600SPT

TRANSISTORS & INTREGATED CIRCUITS

7101	4822 209 17398	LD1117DT33
7102	9322 165 15685	IC SM NCP303LSN30 (ONSE) R
7106	4822 130 11565	2SB1132
7107	4822 130 11565	2SB1132
7108	9322 212 30685	FET POW SM TN0200T (VISH) R
7108	9340 547 13215	FET SIG SM BSH103 (PHSE) R
(ALT)		
7109	9322 212 30685	FET POW SM TN0200T (VISH) R
7109	9340 547 13215	FET SIG SM BSH103 (PHSE) R
(ALT)		
7110	9340 219 30115	BC817-25W
7111	9322 201 94668	IC SM MM1646XH (MITM) R
7112	9322 219 32671	IC SM MT1389EE/B-L (MEDI) Y
7121	9340 425 20115	TRA SIG SM BC847BS (PHSE) R
7131	9965 000 04199	BSN20
7132	9965 000 04199	BSN20
7301	9322 189 04668	IC SM M24C16-RDW6 (ST00) R
7302	9322 166 67668	IC SM MT48LC4M16A2TG-7E(MRN0)R
7302	9322 209 02668	IC SM IS42S16400B-7T (ISSI) R
ALT1		
7302	9322 209 03668	IC SM IS42S16400B-7TL (ISSI) R
ALT2		
7302	9322 166 67668	IC SM MT48LC4M16A2TG-7E(MRN0)R
ALT3		
7304	9322 185 10668	IC SM CS8415A-CZ (CILO) R
7306	9352 687 20125	IC SM 74LVC1G125GW (PHSE) R
7309	3139 240 51231	FLASH EMBEDDED SW (HTS5500)
7310	4822 209 17345	M62320FP

ELECTRICAL PARTS LIST - SET WIRING FOR HTS5500**MISCELLANEOUS**

8000	3139 241 01001	FFC FOIL 08P/180/08P AD 1MMP
8001	3139 241 00801	FFC FOIL 15P/220/15P BD 1MMP
8002	3139 111 04271	FFC FOIL 30P/060/30P BD 1MMP
8003	3139 241 00991	FFC FOIL 20P/060/20P BD 1MMP
8004	3139 111 02421	FFC FOIL 16P/220/16P AD 1MMP
8005	3139 111 04571	FFC FOIL 30P/280 BD 1MMP FOLD
8007	3139 241 00701	FFC FOIL 07P/480/07P BD 1MMP
8008	3139 241 00761	FFC FOIL 09P/400/09P AD 1MMP
8009	3103 308 93911	FFC FOIL 11P/100/11P AD